



<http://www.ebiz-tcf.eu>

IMPLEMENTATION GUIDE

includes COMPARISON BETWEEN CURRENT and LAST
PREVIOUSLY RELEASED VERSION

TRANSACTION "YARN PURCHASE ORDER RESPONSE"

Version: v2018-1

Date of release: 18/7/2019

Document code: G031rv

technical Documentation: <http://www.ebiz.enea.it>

XML Schemas repository: <http://www.ebiz.enea.it/moda-ml/repository/schema/v2018-1/default.asp>

Guides repository: <http://www.ebiz.enea.it/moda-ml/repository/guide/v2018-1/default.asp>

Guide filename: G031rv-eBIZ-YarnPurchaseOrderResponse.pdf

1. BUSINESS DESCRIPTION

1.1 Scope

The present guide has been issued to assist the companies of the Textile-Clothing sector in the implementation of the standard XML document type "YARN ORDER RESPONSE ", providing all the instruction required for its use in any context of e-commerce between Fabric and Yarn Producers. All the rules required for the construction and validation of the document are embedded into the specific XML-Schema, which is detailed in section "Implementation guide".

1.2 Generalities

The message is issued by the Yarn Producer in response to a purchase order.

The Producer must, in any case, return an Order Response for any Order received, where, for each item, he notifies the acceptance as it is (C), the variation (V) or the cancellation (A).

Basic function of the message is to notify acceptance or to request modifications or cancellations concerning:

- 1) suppliable quantities
- 2) dates and places of delivery
- 3) prices

The Order Response can show a number of lines different from the related Purchase Order, when variations/cancellations have occurred so as to create the splitting of an Order Line.

However the sum of the quantities of the lines in the Order Change (confirmed + varied + cancelled) must always not less than the sum of the quantities in the original Order.

When the quantity is change the original line must be splitted and the confirmed amount and canceled amount should be explicated through the 'act' flag.

1.3. Possible scenario

Purchase of yarns

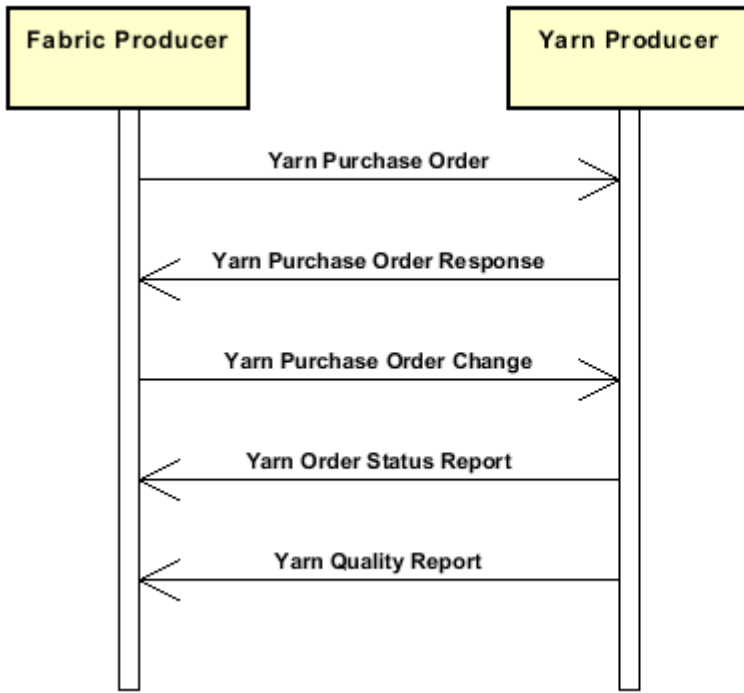

2. IMPLEMENTATION GUIDE

2.1 General structure of XML document

All the business data that can be exchanged through this class of documents are shown in the following "document structure", that provides a simplified vision of the Schema.

In particular:

- the two numbers following each element define its "cardinality" (minimum and maximum number of occurrences); the minimum equal zero indicates that the element is optional, the minimum greater than zero indicates that is mandatory;
- the bold character denotes the complex elements (aggregates of simple elements) that were built for the sake of functionality and re-usability of some complex informations sets. The child elements in each parent element are easily spotted as "indented";
- the symbol "@" denotes an attribute of the preceding element; here "the usage indicator (optional, required, ...)" is shown in square brackets.

Legenda

- N: new element
- U: updated properties
- P: changes in children
- p: is a changed child
- A: changes in attributes
- a: is a new or changed attribute
- *: is a subtype

Structure

YARNOrdResponse

@Totype [Optional]

@msgfunction [Optional] [Default= OR]

@version [Optional] [Default= 2018-1]

@useProfile [Optional]

```
| YXheader 1-1 (P)
| | msgN 1-1
| | - choose -
| | msgID 0-1
| | - or -
| | docID 0-1
| | @numberingOrg [Optional]
| | - end choose -
| | msgDate 1-1
| | @dateForm [Optional]
| | msgCurrency 0-1
| | otherCurrency 0-9 (A)
| | @currencyUseQualifier [Required]
| | @exchangeRate [Optional] (N)
| | refDoc 1-9 (P)
| | @docType [Required]
| | | docID 1-2 (p)
| | | @numberingOrg [Optional]
| | | docDate 0-1
| | | @dateForm [Optional]
| | | season 0-1 (A)
| | | @numberingOrg [Optional] (a)
| | | @codeList [Optional] (a)
| | | @listName [Optional] (a)
| | | @listVersion [Optional] (a)
```

```

| itemID 0-1 (U)
| attachment 0-1 (N)
|   @uid [Optional]
|   | fileName 0-1 (N)
|   |   @numberingOrg [Optional]
|   | binaryObject 0-1 (N)
|   |   @format [Optional] (N)
|   |   @mime [Optional] (N)
|   |   @encoding [Optional] (N)
|   |   @characterSet [Optional] (N)
|   | externalReference 0-99 (N)
|   |   | uri 1-1 (N)
|   |   |   @isURL [Optional] [Default= true] (Na)
|   |   |   mimeTypeCode 0-1 (N)
|   |   |   formatCode 0-1 (N)
|   |   |   encodingCode 0-1 (N)
|   |   |   characterSetCode 0-1 (N)
| buyer 1-1 (AP)
|   @logo [Optional]
|   @sender [Optional] (a*)
|   | id 1-1 (p)
|   |   @numberingOrg [Optional]
|   | additionalIdentifier 0-9 (N)
|   |   @numberingOrg [Optional] (a)
|   |   @idQualifier [Optional] (Na)
|   | legalName 0-1 (U)
|   | dept 0-1
|   | subDept 0-1 (N)
|   | person 0-1
|   |   @email [Optional]
|   |   @phone [Optional]
|   |   @fax [Optional]
|   | street 0-1
|   | city 0-1
|   | subCountry 0-1
|   | country 0-1
|   | postCode 0-1
| supplier 1-1 (AP)
|   @logo [Optional]
|   @sender [Optional] (a*)
|   | id 1-1
|   |   @numberingOrg [Optional]
|   | additionalIdentifier 0-9 (N)
|   |   @numberingOrg [Optional] (a)
|   |   @idQualifier [Optional] (Na)
|   | legalName 0-1 (U)
|   | dept 0-1
|   | subDept 0-1 (N)
|   | person 0-1
|   |   @email [Optional]
|   |   @phone [Optional]
|   |   @fax [Optional]
|   | street 0-1
|   | city 0-1
|   | subCountry 0-1
|   | country 0-1
|   | postCode 0-1
| thirdParty 0-5 (AP)
|   @VAT [Optional]
|   @role [Required]
|   @sender [Optional] (a*)

```

- | | id 1-1
- | | | @numberingOrg [Optional]
- | | legalName 0-1 (U)
- | | dept 0-1
- | | subDept 0-1 (N)
- | | person 0-1
- | | | @email [Optional]
- | | | @phone [Optional]
- | | | @fax [Optional]
- | | street 0-1
- | | city 0-1
- | | subCountry 0-1
- | | country 0-1
- | | postCode 0-1
- | | note 0-99
- | | | @numberingOrg [Optional]
- | | | @codeList [Optional]
- | | | @noteLabel [Optional]

| **terms 0-1 (P)**

- | | **payment 0-5**
- | | | @finDiscount [Optional]
- | | | @finSurcharge [Optional]
- | | - choose -
- | | | payTerm 1-1
- | | - or -
- | | | payTermText 1-1 (U)
- | | - end choose -
- | | | payMode 0-1
- | | **insPayment 0-5**
- | | | @part [Required]
- | | - choose -
- | | | payTerm 1-1
- | | - or -
- | | | payTermText 1-1 (U)
- | | - end choose -
- | | | payMode 0-1
- | | **trade 0-1**
- | | - choose -
- | | | incoTermText 1-1 (U)
- | | - or -
- | | | incoTerm 1-1
- | | - end choose -
- | | | location 0-1
- | | | @LRI [Optional]
- | | **transInfo 0-5 (pAP)**
- | | | @transReason [Optional]
- | | | @progr [Optional] (N)
- | | | transMode 1-1
- | | | carrier 0-1
- | | | deliveryPlace 0-1 (U)
- | | | grossWeight 0-1
- | | | | @um [Required]
- | | | netWeight 0-1
- | | | | @um [Required]
- | | | transMeans 0-1
- | | | transCondition 0-3
- | | | transConditionText 0-1 (U)
- | | | despatchPlace 0-1 (N)
- | | | despatchDate 0-1 (N)
- | | | @dateForm [Optional] (a)

```

| | | delEffectiveDate 0-1 (p)
| | | @dateForm [Optional]
| | allowanceCharge 0-9 (A)
| | @um [Optional] (a)
| | @VAT [Optional]
| | @minQty [Optional] (a)
| | @currency [Optional] (a)
| | @maxQty [Optional] (N)
| | @isCharge [Optional] (N)
| | - choose -
| | | AC_category 1-1
| | | - or -
| | | AC_categoryText 1-1 (U)
| | | - end choose -
| | | - choose -
| | | AC_percent 1-1
| | | - or -
| | | AC_amount 1-1 (A)
| | | @currency [Optional] (a)
| | | - end choose -
| | | dtScheme 0-1 (P)
| | | @taxType [Required]
| | | taxCategory 0-1
| | | taxRate 0-1
| | | legalRef 0-1 (A)
| | | @numberingOrg [Optional]
| | | @codeList [Optional]
| | | @listName [Optional]
| | | @listVersion [Optional]
| | | note 0-99
| | | @numberingOrg [Optional]
| | | @codeList [Optional]
| | | @noteLabel [Optional]

```

```

| | yarnComInfo 0-1 (AP)
| | @endUse [Optional] [Default= PR] (a)
| | season 0-1 (Ap)
| | @numberingOrg [Optional] (a)
| | @codeList [Optional] (a)
| | @listName [Optional] (a)
| | @listVersion [Optional] (a)
| | brand 0-1 (N)
| | @numberingOrg [Optional] (a)
| | @codeList [Optional] (a)
| | @listName [Optional] (a)
| | @listVersion [Optional] (a)
| | productLine 0-1 (N)
| | @numberingOrg [Optional] (a)
| | @codeList [Optional] (a)
| | @listName [Optional] (a)
| | @listVersion [Optional] (a)
| | project 0-1 (pU)
| | operationalCode 0-19 (N)
| | @numberingOrg [Optional] (a)
| | @codeList [Optional] (a)
| | @listName [Optional] (a)
| | @listVersion [Optional] (a)
| | @codeQualifier [Optional] (Na)
| | yarnPay 0-1
| | @percCond [Optional]
| | deliveryDate 0-1

```

- | | *@dateForm* [Optional]
- | specDate 0-1
- | | *@dateForm* [Optional]
- | | **yarnPack 0-1**
- | | | **yarnReel 1-1**
- | | | | *@reelType* [Required]
- | | | | *@reelMat* [Optional]
- | | | | yarnReelD 0-1
- | | | | | *@um* [Required]
- | | | | yarnReelH 0-1
- | | | | | *@um* [Required]
- | | | | yarnConeAngle 0-1
- | | | | yarnReelQty 0-2
- | | | | | *@um* [Required]
- | | | | label 0-1
- | | | | labelWrit 0-1
- | | | | **yarnInWrap 0-1**
- | | | | | yarnReelWrap 1-1
- | | | | | label 0-1
- | | | | | labelWrit 0-1
- | | - choose -
- | | | yarnOutWrapText 0-1 (U)
- | | - or -
- | | | yarnOutWrap 0-1
- | | - end choose -
- | | note 0-99
- | | | *@numberingOrg* [Optional]
- | | | *@codeList* [Optional]
- | | | *@noteLabel* [Optional]

| **YXbody 1-1**

- | | **YXitem 1-unbounded** (P)
- | | | *@act* [Required]
- | | | lineN 1-1
- | | | | *@VAT* [Optional]
- | | | | **refDoc 1-9** (P)
- | | | | | *@docType* [Required]
- | | | | | docID 1-2 (p)
- | | | | | | *@numberingOrg* [Optional]
- | | | | | docDate 0-1
- | | | | | | *@dateForm* [Optional]
- | | | | | season 0-1 (A)
- | | | | | | *@numberingOrg* [Optional] (a)
- | | | | | | *@codeList* [Optional] (a)
- | | | | | | *@listName* [Optional] (a)
- | | | | | | *@listVersion* [Optional] (a)
- | | | | | itemID 0-1 (U)
- | | | | | **attachment 0-1** (N)
- | | | | | | *@uid* [Optional]
- | | | | | | | fileName 0-1 (N)
- | | | | | | | | *@numberingOrg* [Optional]
- | | | | | | | binaryObject 0-1 (N)
- | | | | | | | | *@format* [Optional] (N)
- | | | | | | | | *@mime* [Optional] (N)
- | | | | | | | | *@encoding* [Optional] (N)
- | | | | | | | | *@characterSet* [Optional] (N)
- | | | | | | | **externalReference 0-99** (N)
- | | | | | | | | uri 1-1 (N)
- | | | | | | | | | *@isURL* [Optional] [Default= true] (Na)
- | | | | | | | | | mimeTypeCode 0-1 (N)
- | | | | | | | | | formatCode 0-1 (N)

```

| | | | encodingCode 0-1 (N)
| | | | characterSetCode 0-1 (N)
| | | | yarnCode 0-2 (P)
| | | | @numberingOrg [Optional] [Default= CL]
| | | | | art 1-1 (U)
| | | | | | @numberingOrg [Optional]
| | | | | | @codeList [Optional]
| | | | | | @listName [Optional]
| | | | | | @listVersion [Optional]
| | | | | color 0-1
| | | | | | @numberingOrg [Optional]
| | | | | | @codeList [Optional]
| | | | | | @listName [Optional]
| | | | | | @listVersion [Optional]
| | | | | added 0-9
| | | | | | @numberingOrg [Optional]
| | | | | | @addType [Optional]
| | | | | description 0-unbounded (AU)
| | | | | | @ln [Optional] (N)
| | | | | yarnCompos 0-1
| | | | | | percCompos 1-9
| | | | | | @fibre [Required]
| | | | | yarnSpecs 0-99
| | | | | - choose -
| | | | | | yarnCharText 1-1 (U)
| | | | | | - or -
| | | | | | | yarnChar 1-1
| | | | | | - end choose -
| | | | | | | experimValue 0-1
| | | | | | | | @um [Optional]
| | | | | | | | @method [Optional]
| | | | | | | | @application [Optional]
| | | | | | | | @idCO [Optional]
| | | | | | | specValue 0-1
| | | | | | | | @um [Optional]
| | | | | | | | @source [Optional]
| | | | | | | | @method [Optional]
| | | | | | | | @application [Optional]
| | | | | | | | @CV [Optional]
| | | | | | - choose -
| | | | | | | tolerance 0-2
| | | | | | | | @um [Required]
| | | | | | | - or -
| | | | | | | | pcTolerance 0-2
| | | | | | | | | @um [Optional]
| | | | | | | - end choose -
| | | | | | | lotN 0-2
| | | | | | | | @numberingOrg [Optional]
| | | | | | | dyeN 0-2
| | | | | | | | @numberingOrg [Optional]
| | | | | | - choose -
| | | | | | | yarnTreat 0-9
| | | | | | | - or -
| | | | | | | | yarnTreatText 0-9 (N)
| | | | | | | - end choose -
| | | | | | | | qty 0-2
| | | | | | | | | @um [Required]
| | | | | | | | price 0-1 (AU)
| | | | | | | | | @um [Optional]
| | | | | | | | | @priceQualifier [Optional] [Default= NET]
| | | | | | | | | @currency [Optional] (a)

```

comDiscount 0-1
thirdParty 0-3 (AP)
 @VAT [Optional]
 @role [Required]
 @sender [Optional] (a*)
 | id 1-1
 | | @numberingOrg [Optional]
 | legalName 0-1 (U)
 | dept 0-1
 | subDept 0-1 (N)
 | person 0-1
 | | @email [Optional]
 | | @phone [Optional]
 | | @fax [Optional]
 | street 0-1
 | city 0-1
 | subCountry 0-1
 | country 0-1
 | postCode 0-1
yarnComInfo 0-1 (AP)
 @endUse [Optional] [Default= PR] (a)
 | season 0-1 (Ap)
 | | @numberingOrg [Optional] (a)
 | | @codeList [Optional] (a)
 | | @listName [Optional] (a)
 | | @listVersion [Optional] (a)
 | brand 0-1 (N)
 | | @numberingOrg [Optional] (a)
 | | @codeList [Optional] (a)
 | | @listName [Optional] (a)
 | | @listVersion [Optional] (a)
 | productLine 0-1 (N)
 | | @numberingOrg [Optional]
 | | @codeList [Optional]
 | | @listName [Optional]
 | | @listVersion [Optional]
 | project 0-1 (pU)
 | operationalCode 0-19 (N)
 | | @numberingOrg [Optional]
 | | @codeList [Optional]
 | | @listName [Optional]
 | | @listVersion [Optional]
 | | @codeQualifier [Optional] (N)
 | yarnPay 0-1
 | | @percCond [Optional]
 | deliveryDate 0-1
 | | @dateForm [Optional]
 | specDate 0-1
 | | @dateForm [Optional]
yarnPack 0-1
 | | **yarnReel 1-1**
 | | | @reelType [Required]
 | | | @reelMat [Optional]
 | | | | yarnReelD 0-1
 | | | | | @um [Required]
 | | | | yarnReelH 0-1
 | | | | | @um [Required]
 | | | | yarnConeAngle 0-1
 | | | | yarnReelQty 0-2
 | | | | | @um [Required]
 | | | label 0-1

| | | | | | labelWrit 0-1
 | | | | | | **yarnInWrap 0-1**
 | | | | | | | yarnReelWrap 1-1
 | | | | | | | label 0-1
 | | | | | | | labelWrit 0-1
 - choose -
 | | | | | | | yarnOutWrapText 0-1 (U)
 - or -
 | | | | | | | yarnOutWrap 0-1
 - end choose -
 | | | | | | | note 0-99
 | | | | | | | @numberingOrg [Optional]
 | | | | | | | @codeList [Optional]
 | | | | | | | @noteLabel [Optional]
 | | **dtScheme 0-1** (P)
 | | @taxType [Required]
 | | | taxCategory 0-1
 | | | taxRate 0-1
 | | | legalRef 0-1 (A)
 | | | | @numberingOrg [Optional] (a)
 | | | | @codeList [Optional] (a)
 | | | | @listName [Optional] (a)
 | | | | @listVersion [Optional] (a)
 | | | | note 0-99
 | | | | | @numberingOrg [Optional]
 | | | | | @codeList [Optional]
 | | | | | @noteLabel [Optional]
 | | | note 0-99
 | | | | @numberingOrg [Optional]
 | | | | @codeList [Optional]
 | | | | @noteLabel [Optional]

| totals 0-1
 | | totQty 0-1
 | | | @um [Required]
 | | goodsAmount 1-1 (A)
 | | | @currency [Optional] (a)

2.2 Detailed description of document elements

Following tables show all elements (complex and simple) used in this document. Description includes: 1) element's information: xml tag, name, brief description, data type and syntax constraints; 2) information about use of the element in a particular position in the document: xpath and possible associated notes.

2.2.1 Complex elements (Aggregate Business Information Entities)

Complex elements are those elements whose content is composed of other elements (childs). Complex elements are alphabetically ordered.

allowanceCharge	Allowances and Charges related to an Order or a contract (XPath YARNOrdResponse/terms/allowanceCharge) 0-9 (A)
attachment	an attached document. An attachment can refer to an external document or be included with the document being exchanged (XPath YARNOrdResponse/YXbody/YXitem/refDoc/attachment) 0-1 (N) (XPath YARNOrdResponse/YXheader/refDoc/attachment) 0-1 (N)
buyer	details of the Buyer (party that buys the good or service that is object of the current collaborative process) - base type: Nad, (XPath YARNOrdResponse/YXheader/buyer) 1-1 (AP)
dtScheme	set of data usable to declare the duty or tax applied (XPath YARNOrdResponse/YXbody/YXitem/dtScheme) 0-1 (P) - note: <i>recommended alternative to the attribute @VAT</i> (XPath YARNOrdResponse/terms/allowanceCharge/dtScheme) 0-1 (P)
externalReference	details about an external object, such as a document stored at a remote location (XPath YARNOrdResponse/YXheader/refDoc/attachment/externalReference) 0-99 (N) (XPath YARNOrdResponse/YXbody/YXitem/refDoc/attachment/externalReference) 0-99 (N)
insPayment	payment details for payment by installments (XPath YARNOrdResponse/terms/insPayment) 0-5 - note: <i>excluded the case of offers, this set of data is alternative to payment set and must be iterated for each payment installment</i>
payment	payment details for payment all in one (XPath YARNOrdResponse/terms/payment) 0-5 - note: <i>excluded the case of offers, this set of data is alternative to insPayment, it can be iterated to specify alternative terms of payment (e.g.: 60 days or 30 days with 3% discount)</i>
refDoc	identification of a document and of an item thereof, to which the message makes reference (XPath YARNOrdResponse/YXheader/refDoc) 1-9 (P) - note: <i>At least one occurrence should contain a reference to the order it responds to (for example docType=ORD or OCH or BOR)</i> (XPath YARNOrdResponse/YXbody/YXitem/refDoc) 1-9 (P) - note: <i>Use to link the line of the present document to the line of the order, use refDoc element; numberingOrg indicates the role that produced the document and such reference, customer or supplier (both might be reported through two instances of refDoc)</i>
supplier	details of the Supplier (party that supplies the good or service that is object of the current collaborative process) - base type: Nad, (XPath YARNOrdResponse/YXheader/supplier) 1-1 (AP)

terms	details of the commercial obligations for payment and delivery (XPath YARNOrdResponse/terms) 0-1 (P)
thirdParty	details of the Third Party, different from Sender and Receiver of the document - base type: Nad, (XPath YARNOrdResponse/YXheader/thirdParty) 0-5 (AP) (XPath YARNOrdResponse/YXbody/YXitem/thirdParty) 0-3 (AP)
totals	monetary and quantity totals of the Order (XPath YARNOrdResponse/totals) 0-1
trade	general terms of trade for the specified supply (XPath YARNOrdResponse/terms/trade) 0-1
transInfo	details of transport: mode, carrier and delivery place (XPath YARNOrdResponse/terms/transInfo) 0-5 (pAP)
yarnCode	full codification of a yarn product (XPath YARNOrdResponse/YXbody/YXitem/yarnCode) 0-2 (P)
yarnComInfo	miscellaneous trade information, that can be specified in a yarn Order, referred either to the whole document or to the single item (XPath YARNOrdResponse/yarnComInfo) 0-1 (AP) (XPath YARNOrdResponse/YXbody/YXitem/yarnComInfo) 0-1 (AP)
yarnCompos	fibrous composition of a yarn product (XPath YARNOrdResponse/YXbody/YXitem/yarnCompos) 0-1
yarnInWrap	details specifying the inner wrapping of a yarn product (XPath YARNOrdResponse/YXbody/YXitem/yarnComInfo/yarnPack/yarnInWrap) 0-1 (XPath YARNOrdResponse/yarnComInfo/yarnPack/yarnInWrap) 0-1
yarnPack	details of type of presentation used for the yarn (XPath YARNOrdResponse/YXbody/YXitem/yarnComInfo/yarnPack) 0-1 (XPath YARNOrdResponse/yarnComInfo/yarnPack) 0-1
yarnReel	details of the packaging of a yarn product (bobbin and reel,..) (XPath YARNOrdResponse/YXbody/YXitem/yarnComInfo/yarnPack/yarnReel) 1-1 (XPath YARNOrdResponse/yarnComInfo/yarnPack/yarnReel) 1-1
yarnSpecs	technical properties of a yarn product linked to an operation of the sub-contracted production of yarn or to the purchase of yarn (XPath YARNOrdResponse/YXbody/YXitem/yarnSpecs) 0-99
YXbody	body of the YARN ORDER RESPONSE and YARN ORDER CHANGE (XPath YARNOrdResponse/YXbody) 1-1
YXheader	header of the YARN ORDER RESPONSE and YARN ORDER CHANGE (XPath YARNOrdResponse/YXheader) 1-1 (P)
YXitem	line item of the YARN ORDER RESPONSE and YARN ORDER CHANGE (XPath YARNOrdResponse/YXbody/YXitem) 1-unbounded (P)

2.2.2 Simple elements (Basic Business Information Entities)

Simple elements are those elements whose content is characterized by a data type plus a domain of possible values. Simple elements are alphabetically ordered.

AC_amount	amount of an Allowance or Charge - base type: decimal, fraction digits: 2, (XPath YARNOrdResponse/terms/allowanceCharge/AC_amount) 1-1 (A)
------------------	--

AC_category	<p>coded specification of an Allowance or Charge</p> <p>- base type: string, cod. table: T41 http://www.ebiz.enea.it/moda-ml/repository/codelist/v2018-1/gc_T41.xml (XPath YARNOrdResponse/terms/allowanceCharge/AC_category) 1-1</p>
AC_categoryText	<p>free text description of an Allowance or Charge</p> <p>- base type: string, max length: 250, (XPath YARNOrdResponse/terms/allowanceCharge/AC_categoryText) 1-1 (U)</p>
AC_percent	<p>amount of an Allowance or Charge as a percentage (always non negative value)</p> <p>- base type: decimal, max inclusive: 100, fraction digits: 2, (XPath YARNOrdResponse/terms/allowanceCharge/AC_percent) 1-1</p>
@act	<p>status that the current line assigns to the line addressed in the reference document; if it is already canceled it maintains the status.</p> <p>- base type: string, cod. table: NT5 http://www.ebiz.enea.it/moda-ml/repository/codelist/v2018-1/gc_NT5.xml (XPath YARNOrdResponse/YXbody/YXitem/@act) [Required]</p>
added	<p>additional code of the product (complementing the formers)</p> <p>- base type: string, max length: 80, (XPath YARNOrdResponse/YXbody/YXitem/yarnCode/added) 0-9 - note: <i>here an additional codification (see table T44) can be specified</i></p>
additionalIdentifier	<p>additional identification code of a Party, for example customs registries or others</p> <p>- base type: string, max length: 15, (XPath YARNOrdResponse/YXheader/buyer/additionalIdentifier) 0-9 (N) - note: <i>identifiers for example for exports, such as MID (Manufacturer Identification Code), EORI (E.O.R.I. - Economic Operator Registration and Identification)</i> (XPath YARNOrdResponse/YXheader/supplier/additionalIdentifier) 0-9 (N) - note: <i>identifiers for example for exports, such as MID (Manufacturer Identification Code), EORI (E.O.R.I. - Economic Operator Registration and Identification)</i></p>
@addType	<p>qualifier of the additional coding of a product</p> <p>- base type: string, cod. table: T44 http://www.ebiz.enea.it/moda-ml/repository/codelist/v2018-1/gc_T44.xml (XPath YARNOrdResponse/YXbody/YXitem/yarnCode/added/@addType) [Optional] - nota: <i>addType allows the clarification of the meaning of the added element content; it is strongly suggested to use it always.</i></p>
@application	<p>force or similar condition (e.g. no. of revolutions) applied in a test as specified within the standard</p> <p>- base type: string, max length: 15, (XPath YARNOrdResponse/YXbody/YXitem/yarnSpecs/experimValue/@application) [Optional] (XPath YARNOrdResponse/YXbody/YXitem/yarnSpecs/specValue/@application) [Optional]</p>
art	<p>article number of the product</p> <p>- base type: string, max length: 80, (XPath YARNOrdResponse/YXbody/YXitem/yarnCode/art) 1-1 (U)</p>
binaryObject	<p>a binary large object containing an attached document, Coding 'base64Binary' is recommended.</p> <p>- base type: base64Binary, (XPath YARNOrdResponse/YXbody/YXitem/refDoc/attachment/binaryObject) 0-1 (N) (XPath YARNOrdResponse/YXheader/refDoc/attachment/binaryObject) 0-1 (N)</p>
brand	<p>A brand name.</p> <p>- base type: string, (XPath YARNOrdResponse/yarnComInfo/brand) 0-1 (N)</p>

	(XPath YARNOrdResponse/YXbody/YXitem/yarnComInfo/brand) 0-1 (N)
carrier	identification of the transport carrier - base type: string, max length: 40, (XPath YARNOrdResponse/terms/transInfo/carrier) 0-1
@characterSet	the character set of the binary object (examples UTF-8, UTF-16, Windows-1252, ISO-8859-7,...) - base type: normalizedString, (XPath YARNOrdResponse/YXbody/YXitem/refDoc/attachment/binaryObject/@characterSet) [Optional] (N) (XPath YARNOrdResponse/YXheader/refDoc/attachment/binaryObject/@characterSet) [Optional] (N)
characterSetCode	the character set of an external document (examples UTF-8, UTF-16, Windows-1252, ISO-8859-7,...) - base type: normalizedString, (XPath YARNOrdResponse/YXheader/refDoc/attachment/externalReference/characterSetCode) 0-1 (N) (XPath YARNOrdResponse/YXbody/YXitem/refDoc/attachment/externalReference/characterSetCode) 0-1 (N)
city	name of the city (town, village) - base type: string, max length: 40, (XPath YARNOrdResponse/YXheader/buyer/city) 0-1 (XPath YARNOrdResponse/YXheader/thirdParty/city) 0-1 (XPath YARNOrdResponse/YXbody/YXitem/thirdParty/city) 0-1 (XPath YARNOrdResponse/YXheader/supplier/city) 0-1
@codeList	it specifies the URL where the list of codes used to make an instance of the element can be found - base type: string, max length: 255, (XPath YARNOrdResponse/yarnComInfo/operationalCode/@codeList) [Optional] (a) - nota: at least one out of this attribute and "numberingOrg" should be set (XPath YARNOrdResponse/yarnComInfo/productLine/@codeList) [Optional] (a) - nota: at least one out of this attribute and "numberingOrg" should be set (XPath YARNOrdResponse/YXheader/note/@codeList) [Optional] - nota: must be used to provide (URL) the list of codes used in "noteLabel" (XPath YARNOrdResponse/terms/allowanceCharge/dtScheme/legalRef/@codeList) [Optional] (XPath YARNOrdResponse/yarnComInfo/brand/@codeList) [Optional] (a) - nota: at least one out of this attribute and "numberingOrg" should be set (XPath YARNOrdResponse/YXbody/YXitem/dtScheme/legalRef/@codeList) [Optional] (a) (XPath YARNOrdResponse/yarnComInfo/season/@codeList) [Optional] (a) - nota: this attribute should be used either single or coupled with "listName" and "listVersion" (XPath YARNOrdResponse/YXbody/YXitem/yarnComInfo/note/@codeList) [Optional] - nota: must be used to provide (URL) the list of codes used in "noteLabel" (XPath YARNOrdResponse/terms/allowanceCharge/dtScheme/note/@codeList) [Optional] - nota: must be used to provide (URL) the list of codes used in "noteLabel" (XPath YARNOrdResponse/YXbody/YXitem/yarnCode/color/@codeList) [Optional] - nota: this attribute should be used either single or coupled with "listName" and "listVersion" (XPath YARNOrdResponse/yarnComInfo/note/@codeList) [Optional] - nota: must be used to provide (URL) the list of codes used in "noteLabel" (XPath YARNOrdResponse/YXheader/refDoc/season/@codeList) [Optional] (a) - nota: this attribute should be used either single or coupled with "listName" and "listVersion" (XPath YARNOrdResponse/YXbody/YXitem/dtScheme/note/@codeList) [Optional] - nota: must be used to provide (URL) the list of codes used in "noteLabel" (XPath YARNOrdResponse/YXbody/YXitem/yarnComInfo/brand/@codeList) [Optional] (a) - nota: at least one out of this attribute and "numberingOrg" should be set

	<p>(XPath YARNOrdResponse/YXbody/YXitem/refDoc/season/@codeList) [Optional] (a)</p> <p>- nota: <i>this attribute should be used either single or coupled with "listName" and "listVersion"</i></p> <p>(XPath YARNOrdResponse/YXbody/YXitem/yarnCode/art/@codeList) [Optional]</p> <p>- nota: <i>at least one out of this attribute and "numberingOrg" should be set</i></p> <p>(XPath YARNOrdResponse/YXbody/YXitem/yarnComInfo/season/@codeList) [Optional] (a)</p> <p>- nota: <i>this attribute should be used either single or coupled with "listName" and "listVersion"</i></p> <p>(XPath YARNOrdResponse/YXbody/YXitem/yarnComInfo/operationalCode/@codeList) [Optional]</p> <p>- nota: <i>at least one out of this attribute and "numberingOrg" should be set</i></p> <p>(XPath YARNOrdResponse/YXbody/YXitem/note/@codeList) [Optional]</p> <p>- nota: <i>must be used to provide (URL) the list of codes used in "noteLabel"</i></p> <p>(XPath YARNOrdResponse/YXbody/YXitem/yarnComInfo/productLine/@codeList) [Optional]</p> <p>- nota: <i>at least one out of this attribute and "numberingOrg" should be set</i></p>
@codeQualifier	<p>operational code qualifier: it states if the code is related to a project, an event, an initiative, a sales channel, a management type (eg CITES),</p> <p>- base type: string, cod. table: NT43</p> <p>http://www.ebiz.enea.it/moda-ml/repository/codelist/v2018-1/gc_NT43.xml</p> <p>(XPath YARNOrdResponse/YXbody/YXitem/yarnComInfo/operationalCode/@codeQualifier) [Optional] (N)</p> <p>(XPath YARNOrdResponse/yarnComInfo/operationalCode/@codeQualifier) [Optional] (Na)</p>
color	<p>colour number of the product, when not included in the model or fabric code</p> <p>- base type: string, max length: 15,</p> <p>(XPath YARNOrdResponse/YXbody/YXitem/yarnCode/color) 0-1</p>
comDiscount	<p>percent discount applied to the related unit price or amount</p> <p>- base type: decimal, min inclusive: 0, max inclusive: 100, fraction digits: 2,</p> <p>(XPath YARNOrdResponse/YXbody/YXitem/comDiscount) 0-1</p>
country	<p>code of the nation</p> <p>- base type: string, cod. table: T10</p> <p>http://www.ebiz.enea.it/moda-ml/repository/codelist/v2018-1/gc_T10.xml</p> <p>(XPath YARNOrdResponse/YXbody/YXitem/thirdParty/country) 0-1</p> <p>(XPath YARNOrdResponse/YXheader/buyer/country) 0-1</p> <p>(XPath YARNOrdResponse/YXheader/thirdParty/country) 0-1</p> <p>(XPath YARNOrdResponse/YXheader/supplier/country) 0-1</p>
@currency	<p>currency in which a specified monetary data is expressed</p> <p>- base type: string, cod. table: T9</p> <p>http://www.ebiz.enea.it/moda-ml/repository/codelist/v2018-1/gc_T9.xml</p> <p>(XPath YARNOrdResponse/YXbody/YXitem/price/@currency) [Optional] (a)</p> <p>- nota: <i>Currency referred by the price.</i></p> <p>(XPath YARNOrdResponse/terms/allowanceCharge/@currency) [Optional] (a)</p> <p>(XPath YARNOrdResponse/totals/goodsAmount/@currency) [Optional] (a)</p> <p>(XPath YARNOrdResponse/terms/allowanceCharge/AC_amount/@currency) [Optional] (a)</p>
@currencyUseQualifier	<p>qualification of another currency used in the document</p> <p>- base type: string, cod. table: NT19</p> <p>http://www.ebiz.enea.it/moda-ml/repository/codelist/v2018-1/gc_NT19.xml</p> <p>(XPath YARNOrdResponse/YXheader/otherCurrency/@currencyUseQualifier) [Required]</p>
@CV	<p>coefficient of variation (CV) of a measurement</p> <p>- base type: decimal,</p> <p>(XPath YARNOrdResponse/YXbody/YXitem/yarnSpecs/specValue/@CV) [Optional]</p>
@dateForm	<p>format used for the date</p> <p>- base type: string, cod. table: NT29</p> <p>http://www.ebiz.enea.it/moda-ml/repository/codelist/v2018-1/gc_NT29.xml</p>

	<p>(XPath YARNOrdResponse/terms/transInfo/delEffectiveDate/@dateForm) [Optional] (XPath YARNOrdResponse/terms/transInfo/despatchDate/@dateForm) [Optional] (a)</p> <p>(XPath YARNOrdResponse/YXheader/refDoc/docDate/@dateForm) [Optional] (XPath YARNOrdResponse/YXbody/YXitem/refDoc/docDate/@dateForm) [Optional] (XPath YARNOrdResponse/yarnComInfo/deliveryDate/@dateForm) [Optional] (XPath YARNOrdResponse/yarnComInfo/specDate/@dateForm) [Optional] (XPath YARNOrdResponse/YXbody/YXitem/yarnComInfo/specDate/@dateForm) [Optional] (XPath YARNOrdResponse/YXbody/YXitem/yarnComInfo/deliveryDate/@dateForm) [Optional] (XPath YARNOrdResponse/YXheader/msgDate/@dateForm) [Optional]</p>
delEffectiveDate	<p>effective date of delivery of goods (declared in Despatch), according to one of the patterns YYYY-MM-DD, YYYY-MM-DD:HH-MM or YYYY-WW. - base type: string, (XPath YARNOrdResponse/terms/transInfo/delEffectiveDate) 0-1 (p)</p>
deliveryDate	<p>date of delivery of goods, requested or promised in the purchase process, according to one of the patterns YYYY-MM-DD, YYYY-MM-DD:HH-MM or YY YY-WW. - base type: string, (XPath YARNOrdResponse/YXbody/YXitem/yarnComInfo/deliveryDate) 0-1 (XPath YARNOrdResponse/yarnComInfo/deliveryDate) 0-1</p>
deliveryPlace	<p>place of delivery of goods, ultimate or related to a given leg - base type: string, max length: 250, (XPath YARNOrdResponse/terms/transInfo/deliveryPlace) 0-1 (U)</p>
dept	<p>name or code of a contact department within a Party - base type: string, max length: 40, (XPath YARNOrdResponse/YXbody/YXitem/thirdParty/dept) 0-1 (XPath YARNOrdResponse/YXheader/supplier/dept) 0-1 (XPath YARNOrdResponse/YXheader/buyer/dept) 0-1 (XPath YARNOrdResponse/YXheader/thirdParty/dept) 0-1</p>
description	<p>free text description. The content of the element must be unique, it might be translated and repeated into more languages (thus no more than one instance for each language). - base type: string, max length: 250, (XPath YARNOrdResponse/YXbody/YXitem/yarnCode/description) 0-unbounded (AU) - note: <i>Product description</i></p>
despatchDate	<p>date of despatch of goods, requested or promised in the purchase process, according to one of the patterns YYYY-MM-DD, YYYY-MM-DD:HH-MM or YYYY-WW. - base type: string, (XPath YARNOrdResponse/terms/transInfo/despatchDate) 0-1 (N)</p>
despatchPlace	<p>place of despatch of goods, origin or related to a given leg - base type: string, max length: 250, (XPath YARNOrdResponse/terms/transInfo/despatchPlace) 0-1 (N)</p>
docDate	<p>date of issue of the referenced document, according to one of the patterns YYYY-MM-DD, YYYY-MM-DD:HH-MM or YYYY-WW. - base type: string, (XPath YARNOrdResponse/YXbody/YXitem/refDoc/docDate) 0-1 (XPath YARNOrdResponse/YXheader/refDoc/docDate) 0-1</p>
docID	<p>identification number of the referenced document SINCE 2008-1 ITS USE IN THE HEADER IS DISCOURAGED (REPLACED BY msgID) - base type: string, max length: 80, (XPath YARNOrdResponse/YXheader/refDoc/docID) 1-2 (p)</p> <hr/> <p>AAAA-WARNING! - text not AVAILABLE n. 245 - In=en (XPath YARNOrdResponse/YXheader/docID) 0-1</p>

	<p>(XPath YARNOrdResponse/YXbody/YXitem/refDoc/docID) 1-2 (p)</p> <hr/> <p>AAAA-WARNING! - text not AVAILABLE n. 245 - In=en</p>
@docType	<p>type or class to which the referenced document belongs</p> <p>- base type: string, cod. table: T21 http://www.ebiz.enea.it/moda-ml/repository/codelist/v2018-1/gc_T21.xml (XPath YARNOrdResponse/YXheader/refDoc/@docType) [Required] (XPath YARNOrdResponse/YXbody/YXitem/refDoc/@docType) [Required]</p>
dyeN	<p>number of the dyeing batch of a textile product</p> <p>- base type: string, max length: 15, (XPath YARNOrdResponse/YXbody/YXitem/dyeN) 0-2 - note: <i>it can be specified by the Buyer in case of stock service</i></p>
@email	<p>electronic mail address of the contact person within a Party</p> <p>- base type: string, max length: 250, (XPath YARNOrdResponse/YXheader/supplier/person/@email) [Optional] (XPath YARNOrdResponse/YXbody/YXitem/thirdParty/person/@email) [Optional] (XPath YARNOrdResponse/YXheader/thirdParty/person/@email) [Optional] (XPath YARNOrdResponse/YXheader/buyer/person/@email) [Optional]</p>
@encoding	<p>specifies the decoding algorithm of the binary object</p> <p>- base type: normalizedString, (XPath YARNOrdResponse/YXbody/YXitem/refDoc/attachment/binaryObject/@encoding) [Optional] (N) (XPath YARNOrdResponse/YXheader/refDoc/attachment/binaryObject/@encoding) [Optional] (N)</p>
encodingCode	<p>the encoding/decoding algorithm used with the external object (example is 'base64Binary')</p> <p>- base type: normalizedString, (XPath YARNOrdResponse/YXheader/refDoc/attachment/externalReference/encodingCode) 0-1 (N) (XPath YARNOrdResponse/YXbody/YXitem/refDoc/attachment/externalReference/encodingCode) 0-1 (N)</p>
@endUse	<p>specifies the final use of the fabric</p> <p>- base type: string, cod. table: NT4 http://www.ebiz.enea.it/moda-ml/repository/codelist/v2018-1/gc_NT4.xml (XPath YARNOrdResponse/YXbody/YXitem/yarnComInfo/@endUse) [Optional] [Default= PR] (a) - nota: <i>When used for yarns, use only PR: Production or SA: Sample codes.</i> (XPath YARNOrdResponse/yarnComInfo/@endUse) [Optional] [Default= PR] (a) - nota: <i>When used for yarns, use only PR: Production or SA: Sample codes.</i></p>
@exchangeRate	<p>Currency exchange rate</p> <p>- base type: decimal, min inclusive: 0, (XPath YARNOrdResponse/YXheader/otherCurrency/@exchangeRate) [Optional] (N) - nota: <i>Set the exchange rate of this currency to be applied on the message currency (msgCurrecy) to obtain the final value in this currency.</i></p>
experimValue	<p>experimental value of the measurement</p> <p>- base type: decimal, (XPath YARNOrdResponse/YXbody/YXitem/yarnSpecs/experimValue) 0-1</p>
@fax	<p>fax number of the contact person within a Party</p> <p>- base type: string, max length: 35, (XPath YARNOrdResponse/YXheader/buyer/person/@fax) [Optional] (XPath YARNOrdResponse/YXheader/supplier/person/@fax) [Optional] (XPath YARNOrdResponse/YXheader/thirdParty/person/@fax) [Optional] (XPath YARNOrdResponse/YXbody/YXitem/thirdParty/person/@fax) [Optional]</p>
@fibre	<p>type of fibre used in a textile product</p> <p>- base type: string, cod. table: T19 http://www.ebiz.enea.it/moda-ml/repository/codelist/v2018-1/gc_T19.xml</p>

	(XPath YARNOrdResponse/YXbody/YXitem/yarnCompos/percCompos/@fibre) [Required]
fileName	unique identifier (name) of the file - base type: string, max length: 255, (XPath YARNOrdResponse/YXheader/refDoc/attachment/fileName) 0-1 (N) (XPath YARNOrdResponse/YXbody/YXitem/refDoc/attachment/fileName) 0-1 (N)
@finDiscount	financial discount rate applied for payment by the date specified - base type: decimal, min inclusive: 0, max inclusive: 100, fraction digits: 2, (XPath YARNOrdResponse/terms/payment/@finDiscount) [Optional]
@finSurcharge	financial surcharge rate applied for payment after the date specified - base type: decimal, min inclusive: 0, max inclusive: 100, fraction digits: 2, (XPath YARNOrdResponse/terms/payment/@finSurcharge) [Optional]
@format	the format of the binary content (examples xml, pdf, doc,...) - base type: string, (XPath YARNOrdResponse/YXheader/refDoc/attachment/binaryObject/@format) [Optional] (N) (XPath YARNOrdResponse/YXbody/YXitem/refDoc/attachment/binaryObject/@format) [Optional] (N)
formatCode	the format of the external object (examples xml, pdf, doc,...) - base type: normalizedString, (XPath YARNOrdResponse/YXheader/refDoc/attachment/externalReference/formatCode) 0-1 (N) (XPath YARNOrdResponse/YXbody/YXitem/refDoc/attachment/externalReference/formatCode) 0-1 (N)
goodsAmount	total monetary value of the goods and services considered in the message - base type: decimal, min inclusive: 0, fraction digits: 2, (XPath YARNOrdResponse/totals/goodsAmount) 1-1 (A)
grossWeight	the gross weight, declared for transport or customs purpose - base type: decimal, min inclusive: 0, fraction digits: 2, (XPath YARNOrdResponse/terms/transInfo/grossWeight) 0-1
id	primary identification code of a Party; it is recommended the format: nation code (ISO 3166) + VAT identification number (11 crt), with the qualifier "numberingOrg"= MF - base type: string, max length: 15, (XPath YARNOrdResponse/YXheader/thirdParty/id) 1-1 (XPath YARNOrdResponse/YXbody/YXitem/thirdParty/id) 1-1 (XPath YARNOrdResponse/YXheader/supplier/id) 1-1 (XPath YARNOrdResponse/YXheader/buyer/id) 1-1 (p)
@idCO	primary identification code of the Party executing the test; it is recommended the format: nation code (ISO 3166) + VAT identification number (11 crt). - base type: string, max length: 15, (XPath YARNOrdResponse/YXbody/YXitem/yarnSpecs/experimValue/@idCO) [Optional]
@idQualifier	Qualification of the identifier. - base type: string, (XPath YARNOrdResponse/YXheader/buyer/additionalIdentifier/@idQualifier) [Optional] (Na) - nota: this attribute should be used when the numberingOrg attribute is not enough to declare the type of identifier (XPath YARNOrdResponse/YXheader/supplier/additionalIdentifier/@idQualifier) [Optional] (Na) - nota: this attribute should be used when the numberingOrg attribute is not enough to declare the type of identifier

incoTerm	<p>specification of the terms of trade (INCOTERMS)</p> <p>- base type: string, cod. table: T3</p> <p>http://www.ebiz.enea.it/moda-ml/repository/codelist/v2018-1/gc_T3.xml</p> <p>(XPath YARNOrdResponse/terms/trade/incoTerm) 1-1</p>
incoTermText	<p>free text specifying the terms of trade (incoterm, location)</p> <p>- base type: string, max length: 250,</p> <p>(XPath YARNOrdResponse/terms/trade/incoTermText) 1-1 (U)</p>
@isCharge	<p>Indicates if the element to which it refers is a charge (true = charge, false = allowance)</p> <p>- base type: boolean, min length: 0,</p> <p>(XPath YARNOrdResponse/terms/allowanceCharge/@isCharge) [Optional] (N)</p>
@isURL	<p>it indicates if the referred element is an URL (true) or not (false)</p> <p>- base type: boolean,</p> <p>(XPath YARNOrdResponse/YXbody/YXitem/refDoc/attachment/externalReference/uri/@isURL) [Optional] [Default= true] (Na)</p> <p>- nota: <i>usage of URLs is recommended</i></p> <p>(XPath YARNOrdResponse/YXheader/refDoc/attachment/externalReference/uri/@isURL) [Optional] [Default= true] (Na)</p> <p>- nota: <i>usage of URLs is recommended</i></p>
itemID	<p>number of the line/item of the referenced document</p> <p>- base type: string, max length: 40,</p> <p>(XPath YARNOrdResponse/YXbody/YXitem/refDoc/itemID) 0-1 (U)</p> <p>(XPath YARNOrdResponse/YXheader/refDoc/itemID) 0-1 (U)</p>
label	<p>indicates if the physical object specified has to be labelled</p> <p>- base type: boolean,</p> <p>(XPath YARNOrdResponse/YXbody/YXitem/yarnComInfo/yarnPack/yarnInWrap/label) 0-1</p> <p>(XPath YARNOrdResponse/YXbody/YXitem/yarnComInfo/yarnPack/yarnReel/label) 0-1</p> <p>(XPath YARNOrdResponse/yarnComInfo/yarnPack/yarnReel/label) 0-1</p> <p>(XPath YARNOrdResponse/yarnComInfo/yarnPack/yarnInWrap/label) 0-1</p>
labelWrit	<p>text that must be written on the lable of a specified physical object when its customization is required</p> <p>- base type: string, max length: 350,</p> <p>(XPath YARNOrdResponse/yarnComInfo/yarnPack/yarnInWrap/labelWrit) 0-1</p> <p>(XPath YARNOrdResponse/YXbody/YXitem/yarnComInfo/yarnPack/yarnReel/labelWrit) 0-1</p> <p>(XPath YARNOrdResponse/yarnComInfo/yarnPack/yarnReel/labelWrit) 0-1</p> <p>(XPath YARNOrdResponse/YXbody/YXitem/yarnComInfo/yarnPack/yarnInWrap/labelWrit) 0-1</p>
legalName	<p>legal name of a Party</p> <p>- base type: string, max length: 250,</p> <p>(XPath YARNOrdResponse/YXheader/thirdParty/legalName) 0-1 (U)</p> <p>(XPath YARNOrdResponse/YXheader/buyer/legalName) 0-1 (U)</p> <p>(XPath YARNOrdResponse/YXheader/supplier/legalName) 0-1 (U)</p> <p>(XPath YARNOrdResponse/YXbody/YXitem/thirdParty/legalName) 0-1 (U)</p>
legalRef	<p>legal reference of the duty or tax or fee category</p> <p>- base type: string,</p> <p>(XPath YARNOrdResponse/terms/allowanceCharge/dtScheme/legalRef) 0-1 (A)</p> <p>(XPath YARNOrdResponse/YXbody/YXitem/dtScheme/legalRef) 0-1 (A)</p>
lineN	<p>number of the line item of the present message (xml document); it is set by the role that produces the document. Usually it is a progressive number, but not always.</p> <p>- base type: positiveInteger, min inclusive: 1, max inclusive: 9999,</p> <p>(XPath YARNOrdResponse/YXbody/YXitem/lineN) 1-1</p>
@listName	<p>the name of the list of codes used to make an instance of the element (it might be thought as descriptive element, i.e. 'fabric printing technologies', or n</p>

	<p>ot, i.e. "T264")</p> <ul style="list-style-type: none"> - base type: string, max length: 40, (XPath YARNOrdResponse/yarnComInfo/operationalCode/@listName) [Optional] (a) - nota: <i>this attribute should always be used coupled with "numberingOrg"</i> (XPath YARNOrdResponse/YXbody/YXitem/yarnComInfo/operationalCode/@listName) [Optional] - nota: <i>this attribute should always be used coupled with "numberingOrg"</i> (XPath YARNOrdResponse/YXbody/YXitem/yarnComInfo/productLine/@listName) [Optional] - nota: <i>this attribute should always be used coupled with "numberingOrg"</i> (XPath YARNOrdResponse/YXbody/YXitem/yarnCode/color/@listName) [Optional] - nota: <i>this attribute should always be used coupled with "numberingOrg"</i> (XPath YARNOrdResponse/YXheader/refDoc/season/@listName) [Optional] (a) - nota: <i>this attribute should always be used coupled with "numberingOrg"</i> (XPath YARNOrdResponse/YXbody/YXitem/yarnComInfo/season/@listName) [Optional] (a) - nota: <i>this attribute should always be used coupled with "numberingOrg"</i> (XPath YARNOrdResponse/YXbody/YXitem/yarnComInfo/brand/@listName) [Optional] (a) - nota: <i>this attribute should always be used coupled with "numberingOrg"</i> (XPath YARNOrdResponse/YXbody/YXitem/refDoc/season/@listName) [Optional] (a) - nota: <i>this attribute should always be used coupled with "numberingOrg"</i> (XPath YARNOrdResponse/YXbody/YXitem/yarnCode/art/@listName) [Optional] - nota: <i>this attribute should always be used coupled with "numberingOrg"</i> (XPath YARNOrdResponse/yarnComInfo/productLine/@listName) [Optional] (a) - nota: <i>this attribute should always be used coupled with "numberingOrg"</i> (XPath YARNOrdResponse/terms/allowanceCharge/dtScheme/legalRef/@listName) [Optional] - nota: <i>this attribute should always be used coupled with "numberingOrg"</i> (XPath YARNOrdResponse/yarnComInfo/brand/@listName) [Optional] (a) - nota: <i>this attribute should always be used coupled with "numberingOrg"</i> (XPath YARNOrdResponse/yarnComInfo/season/@listName) [Optional] (a) - nota: <i>this attribute should always be used coupled with "numberingOrg"</i> (XPath YARNOrdResponse/YXbody/YXitem/dtScheme/legalRef/@listName) [Optional] (a) - nota: <i>this attribute should always be used coupled with "numberingOrg"</i>
<p>@listVersion</p>	<p>it specifie the version of the list of codes used to make an instance of the element</p> <ul style="list-style-type: none"> - base type: string, max length: 6, (XPath YARNOrdResponse/YXbody/YXitem/yarnCode/art/@listVersion) [Optional] - nota: <i>this attribute should always be used coupled with "numberingOrg" and "listName"</i> (XPath YARNOrdResponse/yarnComInfo/season/@listVersion) [Optional] (a) - nota: <i>this attribute should always be used coupled with "numberingOrg" and "listName"</i> (XPath YARNOrdResponse/YXbody/YXitem/yarnCode/color/@listVersion) [Optional] - nota: <i>this attribute should always be used coupled with "numberingOrg" and "listName"</i> (XPath YARNOrdResponse/YXbody/YXitem/yarnComInfo/productLine/@listVersion) [Optional] - nota: <i>this attribute should always be used coupled with "numberingOrg" and "listName"</i> (XPath YARNOrdResponse/terms/allowanceCharge/dtScheme/legalRef/@listVersion) [Optional] - nota: <i>this attribute should always be used coupled with "numberingOrg" and "listName"</i> (XPath YARNOrdResponse/YXbody/YXitem/refDoc/season/@listVersion) [Optional] (a) - nota: <i>this attribute should always be used coupled with "numberingOrg" and "listName"</i> (XPath YARNOrdResponse/yarnComInfo/brand/@listVersion) [Optional] (a)

	<p>- nota: <i>this attribute should always be used coupled with “numberingOrg” and “listName”</i> (XPath YARNOrdResponse/YXbody/YXitem/yarnComInfo/brand/@listVersion) [Optional] (a)</p> <p>- nota: <i>this attribute should always be used coupled with “numberingOrg” and “listName”</i> (XPath YARNOrdResponse/YXheader/refDoc/season/@listVersion) [Optional] (a)</p> <p>- nota: <i>this attribute should always be used coupled with “numberingOrg” and “listName”</i> (XPath YARNOrdResponse/yarnComInfo/productLine/@listVersion) [Optional] (a)</p> <p>- nota: <i>this attribute should always be used coupled with “numberingOrg” and “listName”</i> (XPath YARNOrdResponse/YXbody/YXitem/dtScheme/legalRef/@listVersion) [Optional] (a)</p> <p>- nota: <i>this attribute should always be used coupled with “numberingOrg” and “listName”</i> (XPath YARNOrdResponse/yarnComInfo/operationalCode/@listVersion) [Optional] (a)</p> <p>- nota: <i>this attribute should always be used coupled with “numberingOrg” and “listName”</i> (XPath YARNOrdResponse/YXbody/YXitem/yarnComInfo/season/@listVersion) [Optional] (a)</p> <p>- nota: <i>this attribute should always be used coupled with “numberingOrg” and “listName”</i> (XPath YARNOrdResponse/YXbody/YXitem/yarnComInfo/operationalCode/@listVersion) [Optional]</p> <p>- nota: <i>this attribute should always be used coupled with “numberingOrg” and “listName”</i></p>
@ln	<p>Language code. - base type: string, cod. table: NT60 http://www.ebiz.enea.it/moda-ml/repository/codelist/v2018-1/gc_NT60.xml (XPath YARNOrdResponse/YXbody/YXitem/yarnCode/description/@ln) [Optional] (N)</p>
location	<p>specification of a location - base type: string, max length: 40, (XPath YARNOrdResponse/terms/trade/location) 0-1 - note: <i>place to which the INCOTERM applies</i></p>
@logo	<p>company logo (URL of the image jpeg or gif). It is recommended that the width of the image does not exceed 640 pixel. - base type: string, max length: 255, (XPath YARNOrdResponse/YXheader/supplier/@logo) [Optional] (XPath YARNOrdResponse/YXheader/buyer/@logo) [Optional]</p>
lotN	<p>lot number of a product or batch number of the raw material - base type: string, max length: 15, (XPath YARNOrdResponse/YXbody/YXitem/lotN) 0-2 - note: <i>it can be specified by the Buyer in case of stock service it can be specified by the Buyer in case of stock service</i></p>
@LRI	<p>attribute usable to format a string according to a customized User rule (local rule) - base type: string, cod. table: NT3 http://www.ebiz.enea.it/moda-ml/repository/codelist/v2018-1/gc_NT3.xml (XPath YARNOrdResponse/terms/trade/location/@LRI) [Optional]</p>
@maxQty	<p>maximum product quantity - base type: decimal, min inclusive: 0, fraction digits: 2, (XPath YARNOrdResponse/terms/allowanceCharge/@maxQty) [Optional] (N) - nota: <i>maximum quantity of product for the application of this allowance or charge</i></p>

@method	<p>standard protocol or method employed in a test to evaluate a characteristic or a parameter</p> <ul style="list-style-type: none"> - base type: string, max length: 80, (XPath YARNOrdResponse/YXbody/YXitem/yarnSpecs/experimValue/@method) [Optional] - nota: <i>we recommend the specification of the method of measure only when different from the one of the MODA-ML coding system</i> (XPath YARNOrdResponse/YXbody/YXitem/yarnSpecs/specValue/@method) [Optional]
@mime	<p>the mime type of the binary object</p> <ul style="list-style-type: none"> - base type: normalizedString, (XPath YARNOrdResponse/YXheader/refDoc/attachment/binaryObject/@mime) [Optional] (N) (XPath YARNOrdResponse/YXbody/YXitem/refDoc/attachment/binaryObject/@mime) [Optional] (N)
mimeCode	<p>mime type of the external object</p> <ul style="list-style-type: none"> - base type: normalizedString, (XPath YARNOrdResponse/YXheader/refDoc/attachment/externalReference/mimeCode) 0-1 (N) <hr/> <p>AAAA-WARNING! - text not AVAILABLE n. 245 - In=en (XPath YARNOrdResponse/YXbody/YXitem/refDoc/attachment/externalReference/mimeCode) 0-1 (N)</p> <hr/> <p>AAAA-WARNING! - text not AVAILABLE n. 245 - In=en</p>
@minQty	<p>minimum product quantity</p> <ul style="list-style-type: none"> - base type: decimal, min inclusive: 0, fraction digits: 2, (XPath YARNOrdResponse/terms/allowanceCharge/@minQty) [Optional] (a) - nota: <i>minimum quantity of product for the application of this allowance or charge</i>
msgCurrency	<p>currency used to express the monetary amounts of the message</p> <ul style="list-style-type: none"> - base type: string, cod. table: T9 http://www.ebiz.enea.it/moda-ml/repository/codelist/v2018-1/gc_T9.xml (XPath YARNOrdResponse/YXheader/msgCurrency) 0-1
msgDate	<p>date of issue of the present message (xml document), according to one of the patterns YYYY-MM-DD, YYYY-MM-DD:HH-MM or YYYY-WW.</p> <ul style="list-style-type: none"> - base type: string, (XPath YARNOrdResponse/YXheader/msgDate) 1-1
@msgfunction	<p>function performed by the present message with regards to the transmission</p> <ul style="list-style-type: none"> - base type: string, cod. table: NT18 http://www.ebiz.enea.it/moda-ml/repository/codelist/v2018-1/gc_NT18.xml (XPath YARNOrdResponse/@msgfunction) [Optional] [Default= OR]
msgID	<p>key identifier of the business document in the information system of the issuing Party. In case of more despatches of the same business document, it is unchanged.</p> <ul style="list-style-type: none"> - base type: string, max length: 35, (XPath YARNOrdResponse/YXheader/msgID) 0-1
msgN	<p>identification number given to the message (xml document) by its issuer. In case of more despatches of the same business document, it changes.</p> <ul style="list-style-type: none"> - base type: string, max length: 35, (XPath YARNOrdResponse/YXheader/msgN) 1-1
netWeight	<p>the net weight declared for transport or customs purpose</p> <ul style="list-style-type: none"> - base type: decimal, min inclusive: 0, fraction digits: 2, (XPath YARNOrdResponse/terms/transInfo/netWeight) 0-1
note	<p>free text or structured (computer processing) note. For note structuring use the attributes "noteLabel" and "codelist"</p> <ul style="list-style-type: none"> - base type: string, max length: 350, (XPath YARNOrdResponse/YXbody/YXitem/dtScheme/note) 0-99

	<p>(XPath YARNOrdResponse/YXheader/note) 0-99 (XPath YARNOrdResponse/YXbody/YXitem/yarnComInfo/note) 0-99 (XPath YARNOrdResponse/terms/allowanceCharge/dtScheme/note) 0-99 (XPath YARNOrdResponse/yarnComInfo/note) 0-99 (XPath YARNOrdResponse/YXbody/YXitem/note) 0-99</p>
@noteLabel	<p>subject qualifier of a note - base type: string, max length: 35, (XPath YARNOrdResponse/YXbody/YXitem/yarnComInfo/note/@noteLabel) [Optional]</p> <p>- nota: <i>must be used to qualify the subject of the note</i> (XPath YARNOrdResponse/YXbody/YXitem/dtScheme/note/@noteLabel) [Optional]</p> <p>- nota: <i>must be used to qualify the subject of the note</i> (XPath YARNOrdResponse/yarnComInfo/note/@noteLabel) [Optional]</p> <p>- nota: <i>must be used to qualify the subject of the note</i> (XPath YARNOrdResponse/YXheader/note/@noteLabel) [Optional]</p> <p>- nota: <i>must be used to qualify the subject of the note</i> (XPath YARNOrdResponse/terms/allowanceCharge/dtScheme/note/@noteLabel) [Optional]</p> <p>- nota: <i>must be used to qualify the subject of the note</i> (XPath YARNOrdResponse/YXbody/YXitem/note/@noteLabel) [Optional]</p> <p>- nota: <i>must be used to qualify the subject of the note</i></p>
@numberingOrg	<p>code specifying the organisation who has created or owns the coding or numbering system - base type: string, cod. table: NT6 http://www.ebiz.enea.it/moda-ml/repository/codelist/v2018-1/gc_NT6.xml (XPath YARNOrdResponse/YXbody/YXitem/yarnCode/added/@numberingOrg) [Optional]</p> <p>- nota: <i>this attribute should be used either single or coupled with "listName" and "listVersion"</i> (XPath YARNOrdResponse/yarnComInfo/productLine/@numberingOrg) [Optional] (a)</p> <p>- nota: <i>this attribute should be used either single or coupled with "listName" and "listVersion"</i> (XPath YARNOrdResponse/YXbody/YXitem/yarnCode/art/@numberingOrg) [Optional]</p> <p>- nota: <i>this attribute should be used either single or coupled with "listName" and "listVersion"</i> (XPath YARNOrdResponse/YXbody/YXitem/yarnCode/color/@numberingOrg) [Optional]</p> <p>- nota: <i>this attribute should be used either single or coupled with "listName" and "listVersion"</i> (XPath YARNOrdResponse/YXbody/YXitem/thirdParty/id/@numberingOrg) [Optional]</p> <p>(XPath YARNOrdResponse/YXbody/YXitem/yarnComInfo/operationalCode/@numberingOrg) [Optional]</p> <p>- nota: <i>this attribute should be used either single or coupled with "listName" and "listVersion"</i> (XPath YARNOrdResponse/yarnComInfo/operationalCode/@numberingOrg) [Optional] (a)</p> <p>- nota: <i>this attribute should be used either single or coupled with "listName" and "listVersion"</i> (XPath YARNOrdResponse/YXheader/refDoc/attachment/fileName/@numberingOrg) [Optional]</p> <p>(XPath YARNOrdResponse/YXbody/YXitem/lotN/@numberingOrg) [Optional]</p> <p>(XPath YARNOrdResponse/YXheader/refDoc/docID/@numberingOrg) [Optional]</p> <p>- nota: <i>here can be specified whose document numbering is used (e.g.: Client, Supplier, ..)</i> (XPath YARNOrdResponse/YXbody/YXitem/dyeN/@numberingOrg) [Optional]</p> <p>(XPath YARNOrdResponse/YXbody/YXitem/yarnComInfo/season/@numberingOrg) [Optional] (a)</p> <p>- nota: <i>this attribute should be used either single or coupled with "listName" and "listVersion"</i> (XPath YARNOrdResponse/YXheader/supplier/id/@numberingOrg) [Optional]</p>

	<p>(XPath YARNOrdResponse/YXbody/YXitem/yarnComInfo/note/@numberingOrg) [Optional]</p> <p>- nota: <i>must be used to specify the organization that created the list of codes used in "noteLabel"</i></p> <p>(XPath YARNOrdResponse/YXheader/note/@numberingOrg) [Optional]</p> <p>- nota: <i>must be used to specify the organization that created the list of codes used in "noteLabel"</i></p> <p>(XPath YARNOrdResponse/YXbody/YXitem/note/@numberingOrg) [Optional]</p> <p>- nota: <i>must be used to specify the organization that created the list of codes used in "noteLabel"</i></p> <p>(XPath YARNOrdResponse/YXheader/supplier/additionalIdentifier/@numberingOrg) [Optional] (a)</p> <p>- nota: <i>here the issuer of the identifier must be specified</i></p> <p>(XPath YARNOrdResponse/YXheader/buyer/id/@numberingOrg) [Optional]</p> <p>(XPath YARNOrdResponse/YXbody/YXitem/refDoc/attachment/fileName/@numberingOrg) [Optional]</p> <p>(XPath YARNOrdResponse/terms/allowanceCharge/dtScheme/note/@numberingOrg) [Optional]</p> <p>- nota: <i>must be used to specify the organization that created the list of codes used in "noteLabel"</i></p> <p>(XPath YARNOrdResponse/YXbody/YXitem/yarnComInfo/productLine/@numberingOrg) [Optional]</p> <p>- nota: <i>this attribute should be used either single or coupled with "listName" and "listVersion"</i></p> <p>(XPath YARNOrdResponse/yarnComInfo/brand/@numberingOrg) [Optional] (a)</p> <p>- nota: <i>this attribute should be used either single or coupled with "listName" and "listVersion"</i></p> <p>(XPath YARNOrdResponse/YXbody/YXitem/dtScheme/legalRef/@numberingOrg) [Optional] (a)</p> <p>- nota: <i>this attribute should be used either single or coupled with "listName" and "listVersion"</i></p> <p>(XPath YARNOrdResponse/YXbody/YXitem/refDoc/season/@numberingOrg) [Optional] (a)</p> <p>- nota: <i>this attribute should be used either single or coupled with "listName" and "listVersion"</i></p> <p>(XPath YARNOrdResponse/yarnComInfo/season/@numberingOrg) [Optional] (a)</p> <p>- nota: <i>this attribute should be used either single or coupled with "listName" and "listVersion"</i></p> <p>(XPath YARNOrdResponse/YXbody/YXitem/dtScheme/note/@numberingOrg) [Optional]</p> <p>- nota: <i>must be used to specify the organization that created the list of codes used in "noteLabel"</i></p> <p>(XPath YARNOrdResponse/yarnComInfo/note/@numberingOrg) [Optional]</p> <p>- nota: <i>must be used to specify the organization that created the list of codes used in "noteLabel"</i></p> <p>(XPath YARNOrdResponse/YXheader/refDoc/season/@numberingOrg) [Optional] (a)</p> <p>- nota: <i>this attribute should be used either single or coupled with "listName" and "listVersion"</i></p> <p>(XPath YARNOrdResponse/YXbody/YXitem/refDoc/docID/@numberingOrg) [Optional]</p> <p>- nota: <i>here can be specified whose document numbering is used (e.g.: Client, Supplier, ..)</i></p> <p>(XPath YARNOrdResponse/YXheader/thirdParty/id/@numberingOrg) [Optional]</p> <p>(XPath YARNOrdResponse/YXbody/YXitem/yarnComInfo/brand/@numberingOrg) [Optional] (a)</p> <p>- nota: <i>this attribute should be used either single or coupled with "listName" and "listVersion"</i></p> <p>(XPath YARNOrdResponse/YXheader/docID/@numberingOrg) [Optional]</p> <p>- nota: <i>here can be specified whose document numbering is used (e.g.: Client, Supplier, ..)</i></p> <p>(XPath YARNOrdResponse/YXbody/YXitem/yarnCode/@numberingOrg) [Optional] [Default= CL]</p>
--	---

	<p>(XPath YARNOrdResponse/terms/allowanceCharge/dtScheme/legalRef/@numberingOrg) [Optional]</p> <p>- nota: <i>this attribute should be used either single or coupled with "listName" and "listVersion"</i></p> <p>(XPath YARNOrdResponse/YXheader/buyer/additionalIdentifier/@numberingOrg) [Optional] (a)</p> <p>- nota: <i>here the issuer of the identifier must be specified</i></p>
operationalCode	<p>operational code: it is the code of a project, an event, an initiative, a sales channel, a management type (eg CITES), ... the document, or product, is connected with.</p> <p>- base type: string,</p> <p>(XPath YARNOrdResponse/yarnComInfo/operationalCode) 0-19 (N)</p> <p>(XPath YARNOrdResponse/YXbody/YXitem/yarnComInfo/operationalCode) 0-19 (N)</p>
otherCurrency	<p>other currency used in the document</p> <p>- base type: string, cod. table: T9</p> <p>http://www.ebiz.enea.it/moda-ml/repository/codelist/v2018-1/gc_T9.xml</p> <p>(XPath YARNOrdResponse/YXheader/otherCurrency) 0-9 (A)</p>
@part	<p>percent fraction of a total payment</p> <p>- base type: decimal, min inclusive: 1, max inclusive: 99, fraction digits: 2,</p> <p>(XPath YARNOrdResponse/terms/insPayment/@part) [Required]</p> <p>- nota: <i>here the % value of each installment must be indicated</i></p>
payMode	<p>way or means of payment</p> <p>- base type: string, cod. table: T2</p> <p>http://www.ebiz.enea.it/moda-ml/repository/codelist/v2018-1/gc_T2.xml</p> <p>(XPath YARNOrdResponse/terms/payment/payMode) 0-1</p> <p>(XPath YARNOrdResponse/terms/insPayment/payMode) 0-1</p>
payTerm	<p>code specifying the terms or time by which the payment must be done</p> <p>- base type: string, cod. table: T1</p> <p>http://www.ebiz.enea.it/moda-ml/repository/codelist/v2018-1/gc_T1.xml</p> <p>(XPath YARNOrdResponse/terms/insPayment/payTerm) 1-1</p> <p>(XPath YARNOrdResponse/terms/payment/payTerm) 1-1</p>
payTermText	<p>free text specifying the terms by which the payment must be done (time/mode or means)</p> <p>- base type: string, max length: 250,</p> <p>(XPath YARNOrdResponse/terms/payment/payTermText) 1-1 (U)</p> <p>(XPath YARNOrdResponse/terms/insPayment/payTermText) 1-1 (U)</p>
pcTolerance	<p>percent deviation tolerated on the value of a measurement (it must have a plus or minus sign)</p> <p>- base type: decimal, min inclusive: 0, max inclusive: 100, total digits: 2,</p> <p>(XPath YARNOrdResponse/YXbody/YXitem/yarnSpecs/pcTolerance) 0-2</p>
percCompos	<p>fiber rate in the product composition</p> <p>- base type: decimal, min inclusive: 0, max inclusive: 100, fraction digits: 2,</p> <p>(XPath YARNOrdResponse/YXbody/YXitem/yarnCompos/percCompos) 1-9</p>
@percCond	<p>percentage of conditioning to be applied to the payment of a yarn supply</p> <p>- base type: decimal, min inclusive: 0, max inclusive: 100, fraction digits: 2,</p> <p>(XPath YARNOrdResponse/YXbody/YXitem/yarnComInfo/yarnPay/@percCond) [Optional]</p> <p>- nota: <i>element to be used only when conditioned payments occur</i></p> <p>(XPath YARNOrdResponse/yarnComInfo/yarnPay/@percCond) [Optional]</p> <p>- nota: <i>element to be used only when conditioned payments occur</i></p>
person	<p>name of the contact person within a Party</p> <p>- base type: string, max length: 40,</p> <p>(XPath YARNOrdResponse/YXheader/supplier/person) 0-1</p> <p>(XPath YARNOrdResponse/YXheader/thirdParty/person) 0-1</p> <p>(XPath YARNOrdResponse/YXheader/buyer/person) 0-1</p> <p>(XPath YARNOrdResponse/YXbody/YXitem/thirdParty/person) 0-1</p>

@phone	<p>phone number of the contact person within a Party</p> <p>- base type: string, max length: 35,</p> <p>(XPath YARNOrdResponse/YXheader/thirdParty/person/@phone) [Optional]</p> <p>(XPath YARNOrdResponse/YXbody/YXitem/thirdParty/person/@phone) [Optional]</p> <p>(XPath YARNOrdResponse/YXheader/supplier/person/@phone) [Optional]</p> <p>(XPath YARNOrdResponse/YXheader/buyer/person/@phone) [Optional]</p>
postCode	<p>code defining the postal zone</p> <p>- base type: string, max length: 10,</p> <p>(XPath YARNOrdResponse/YXheader/buyer/postCode) 0-1</p> <p>(XPath YARNOrdResponse/YXbody/YXitem/thirdParty/postCode) 0-1</p> <p>(XPath YARNOrdResponse/YXheader/supplier/postCode) 0-1</p> <p>(XPath YARNOrdResponse/YXheader/thirdParty/postCode) 0-1</p>
price	<p>unit price of the article, object or service specified</p> <p>- base type: decimal, min inclusive: 0, fraction digits: 4,</p> <p>(XPath YARNOrdResponse/YXbody/YXitem/price) 0-1 (AU)</p>
@priceQualifier	<p>type of price with reference to discount and taxes</p> <p>- base type: string, cod. table: NT20</p> <p>http://www.ebiz.enea.it/moda-ml/repository/codelist/v2018-1/gc_NT20.xml</p> <p>(XPath YARNOrdResponse/YXbody/YXitem/price/@priceQualifier) [Optional] [Default= NET]</p>
productLine	<p>the product line name of a fashion product.</p> <p>- base type: string,</p> <p>(XPath YARNOrdResponse/YXbody/YXitem/yarnComInfo/productLine) 0-1 (N)</p> <p>(XPath YARNOrdResponse/yarnComInfo/productLine) 0-1 (N)</p>
@progr	<p>progressive number in the sequence</p> <p>- base type: positiveInteger, min inclusive: 1,</p> <p>(XPath YARNOrdResponse/terms/transInfo/@progr) [Optional] (N)</p> <p>- nota: <i>Indicates the position of the leg in a sequence of transport legs. If it is declared it must be in all the transInfo elements.</i></p>
project	<p>code used to assign the items ordered (fabric pieces, accessories, garments ...) to a specific project of the Client</p> <p>- base type: string, max length: 40,</p> <p>(XPath YARNOrdResponse/YXbody/YXitem/yarnComInfo/project) 0-1 (pU)</p> <p>(XPath YARNOrdResponse/yarnComInfo/project) 0-1 (pU)</p>
qty	<p>net quantity of the article or object correlated, qualified by the function of the document (ordering, delivering, ..) and by the context</p> <p>- base type: decimal, min inclusive: 0, fraction digits: 2,</p> <p>(XPath YARNOrdResponse/YXbody/YXitem/qty) 0-2</p> <hr/> <p>AAAA-WARNING! - text not AVAILABLE n. 245 - In=en</p>
@reelMat	<p>type of material of which a package for yarn is made</p> <p>- base type: string, cod. table: T30</p> <p>http://www.ebiz.enea.it/moda-ml/repository/codelist/v2018-1/gc_T30.xml</p> <p>(XPath YARNOrdResponse/YXbody/YXitem/yarnComInfo/yarnPack/yarnReel/@reelMat) [Optional]</p> <p>(XPath YARNOrdResponse/yarnComInfo/yarnPack/yarnReel/@reelMat) [Optional]</p>
@reelType	<p>type of package used for a yarn product</p> <p>- base type: string, cod. table: T29</p> <p>http://www.ebiz.enea.it/moda-ml/repository/codelist/v2018-1/gc_T29.xml</p> <p>(XPath YARNOrdResponse/YXbody/YXitem/yarnComInfo/yarnPack/yarnReel/@reelType) [Required]</p> <p>(XPath YARNOrdResponse/yarnComInfo/yarnPack/yarnReel/@reelType) [Required]</p>
@role	<p>Third Party role qualifier</p> <p>- base type: string, cod. table: NT2</p> <p>http://www.ebiz.enea.it/moda-ml/repository/codelist/v2018-1/gc_NT2.xml</p> <p>(XPath YARNOrdResponse/YXheader/thirdParty/@role) [Required]</p> <p>(XPath YARNOrdResponse/YXbody/YXitem/thirdParty/@role) [Required]</p>

season	<p>sale season; defined as: season (1 crt) + year (4 crt) - season: S/S=1 A/W=2 Spring=3 Summer=4 Autumn=5 Winter=6: for more than four seasons use alphabetic sequence: 1st season=A 2nd season=B etc.etc.</p> <p>- base type: string, max length: 15, (XPath YARNOrdResponse/YXbody/YXitem/refDoc/season) 0-1 (A)</p> <p>- note: here indicates the season to which the referenced document belongs (XPath YARNOrdResponse/YXheader/refDoc/season) 0-1 (A)</p> <p>- note: here indicates the season to which the referenced document belongs (XPath YARNOrdResponse/YXbody/YXitem/yarnComInfo/season) 0-1 (Ap) (XPath YARNOrdResponse/yarnComInfo/season) 0-1 (Ap)</p>
@sender	<p>qualifier that specifies the Party issuing of the document</p> <p>- base type: boolean, (XPath YARNOrdResponse/YXheader/thirdParty/@sender) [Optional] (a*)</p> <p>- nota: This attribute is mandatory when the STYLESHEET must be used (XPath YARNOrdResponse/YXheader/supplier/@sender) [Optional] (a*)</p> <p>- nota: This attribute is mandatory when the STYLESHEET must be used (XPath YARNOrdResponse/YXheader/buyer/@sender) [Optional] (a*)</p> <p>- nota: This attribute is mandatory when the STYLESHEET must be used (XPath YARNOrdResponse/YXbody/YXitem/thirdParty/@sender) [Optional] (a*)</p> <p>- nota: This attribute is mandatory when the STYLESHEET must be used</p>
@source	<p>party who has provided the data</p> <p>- base type: string, cod. table: NT12 http://www.ebiz.enea.it/moda-ml/repository/codelist/v2018-1/gc_NT12.xml (XPath YARNOrdResponse/YXbody/YXitem/yarnSpecs/specValue/@source) [Optional]</p>
specDate	<p>date by which the referenced blanket order must receive full product specific ations (e.g.: colour), according to one of the patterns YYYY-MM-DD, YYYY-MM-DD:HH-MM or YYYY-WW.</p> <p>- base type: string, (XPath YARNOrdResponse/yarnComInfo/specDate) 0-1 (XPath YARNOrdResponse/YXbody/YXitem/yarnComInfo/specDate) 0-1</p>
specValue	<p>value requested for a property or a parameter that is measured</p> <p>- base type: decimal, (XPath YARNOrdResponse/YXbody/YXitem/yarnSpecs/specValue) 0-1</p>
street	<p>street and building number identifying a location</p> <p>- base type: string, max length: 80, (XPath YARNOrdResponse/YXbody/YXitem/thirdParty/street) 0-1 (XPath YARNOrdResponse/YXheader/buyer/street) 0-1 (XPath YARNOrdResponse/YXheader/thirdParty/street) 0-1 (XPath YARNOrdResponse/YXheader/supplier/street) 0-1</p>
subCountry	<p>short name or code of the sub-country entity</p> <p>- base type: string, max length: 9, (XPath YARNOrdResponse/YXbody/YXitem/thirdParty/subCountry) 0-1 (XPath YARNOrdResponse/YXheader/supplier/subCountry) 0-1 (XPath YARNOrdResponse/YXheader/buyer/subCountry) 0-1 (XPath YARNOrdResponse/YXheader/thirdParty/subCountry) 0-1</p>
subDept	<p>name or code of a contact department within a Party</p> <p>- base type: string, max length: 40, (XPath YARNOrdResponse/YXheader/buyer/subDept) 0-1 (N) (XPath YARNOrdResponse/YXheader/thirdParty/subDept) 0-1 (N) (XPath YARNOrdResponse/YXbody/YXitem/thirdParty/subDept) 0-1 (N) (XPath YARNOrdResponse/YXheader/supplier/subDept) 0-1 (N)</p>
taxCategory	<p>duty or tax or fee category</p> <p>- base type: string, cod. table: T62 http://www.ebiz.enea.it/moda-ml/repository/codelist/v2018-1/gc_T62.xml (XPath YARNOrdResponse/YXbody/YXitem/dtScheme/taxCategory) 0-1 (XPath YARNOrdResponse/terms/allowanceCharge/dtScheme/taxCategory) 0-1</p>

taxRate	duty or tax or fee percent rate - base type: string, (XPath YARNOrdResponse/YXbody/YXitem/dtScheme/taxRate) 0-1 (XPath YARNOrdResponse/terms/allowanceCharge/dtScheme/taxRate) 0-1
@taxType	duty or tax or fee type - base type: string, cod. table: T61 http://www.ebiz.enea.it/moda-ml/repository/codelist/v2018-1/gc_T61.xml (XPath YARNOrdResponse/terms/allowanceCharge/dtScheme/@taxType) [Required] (XPath YARNOrdResponse/YXbody/YXitem/dtScheme/@taxType) [Required]
tolerance	deviation tolerated on the value of a measurement (it must have a plus or minus sign) - base type: decimal, (XPath YARNOrdResponse/YXbody/YXitem/yarnSpecs/tolerance) 0-2
totQty	total quantity of the articles related to the whole document - base type: decimal, min inclusive: 0, fraction digits: 2, (XPath YARNOrdResponse/totals/totQty) 0-1
@TOtype	type of Order - base type: string, cod. table: NT1 http://www.ebiz.enea.it/moda-ml/repository/codelist/v2018-1/gc_NT1.xml (XPath YARNOrdResponse/@TOtype) [Optional]
transCondition	special condition of transport or special service requested to the Forwarder - base type: string, cod. table: T38 http://www.ebiz.enea.it/moda-ml/repository/codelist/v2018-1/gc_T38.xml (XPath YARNOrdResponse/terms/transInfo/transCondition) 0-3
transConditionText	free text description of the special condition of transport or special service requested to the Forwarder - base type: string, max length: 250, (XPath YARNOrdResponse/terms/transInfo/transConditionText) 0-1 (U)
transMeans	means of transport, in general or referred to a specific leg - base type: string, cod. table: T40 http://www.ebiz.enea.it/moda-ml/repository/codelist/v2018-1/gc_T40.xml (XPath YARNOrdResponse/terms/transInfo/transMeans) 0-1
transMode	way of transport, in general or referred to the specified leg - base type: string, cod. table: T8 http://www.ebiz.enea.it/moda-ml/repository/codelist/v2018-1/gc_T8.xml (XPath YARNOrdResponse/terms/transInfo/transMode) 1-1
@transReason	reason for the transport - base type: string, cod. table: NT11 http://www.ebiz.enea.it/moda-ml/repository/codelist/v2018-1/gc_NT11.xml (XPath YARNOrdResponse/terms/transInfo/@transReason) [Optional]
@uid	unique element identifier within the xml document - base type: string, (XPath YARNOrdResponse/YXbody/YXitem/refDoc/attachment/@uid) [Optional] (XPath YARNOrdResponse/YXheader/refDoc/attachment/@uid) [Optional]
@um	specification of the unit of measure - base type: string, cod. table: NT7 http://www.ebiz.enea.it/moda-ml/repository/codelist/v2018-1/gc_NT7.xml (XPath YARNOrdResponse/YXbody/YXitem/yarnSpecs/specValue/@um) [Optional] (XPath YARNOrdResponse/terms/transInfo/netWeight/@um) [Required] (XPath YARNOrdResponse/YXbody/YXitem/yarnComInfo/yarnPack/yarnReel/yarnReelQty/@um) [Required] (XPath YARNOrdResponse/yarnComInfo/yarnPack/yarnReel/yarnReelH/@um) [Required] (XPath YARNOrdResponse/YXbody/YXitem/yarnSpecs/pcTolerance/@um) [Optional]

	<p>- nota: <i>to be used when it has to be soecified if the declared percentage is b y weight, volume, etc...</i></p> <p>(XPath YARNOrdResponse/YXbody/YXitem/yarnSpecs/experimValue/@um) [Optional]</p> <p>(XPath YARNOrdResponse/totals/totQty/@um) [Required]</p> <p>(XPath YARNOrdResponse/YXbody/YXitem/yarnSpecs/tolerance/@um) [Required]</p> <p>(XPath YARNOrdResponse/terms/transInfo/grossWeight/@um) [Required]</p> <p>(XPath YARNOrdResponse/yarnComInfo/yarnPack/yarnReel/yarnReelQty/@um) [Required]</p> <p>(XPath YARNOrdResponse/terms/allowanceCharge/@um) [Optional] (a)</p> <p>(XPath YARNOrdResponse/YXbody/YXitem/price/@um) [Optional]</p> <p>- nota: <i>Unit of measure of the product to which the price is referred (price pe r meter)</i></p> <p>(XPath YARNOrdResponse/YXbody/YXitem/yarnComInfo/yarnPack/yarnReel/yarnReelD/@um) [Required]</p> <p>(XPath YARNOrdResponse/YXbody/YXitem/yarnComInfo/yarnPack/yarnReel/yarnReelH/@um) [Required]</p> <p>(XPath YARNOrdResponse/yarnComInfo/yarnPack/yarnReel/yarnReelD/@um) [Required]</p> <p>(XPath YARNOrdResponse/YXbody/YXitem/qty/@um) [Required]</p>
uri	<p>Uniform Resource Identifier (URI) that identifies the external object as an Internet resource</p> <p>- base type: normalizedString,</p> <p>(XPath YARNOrdResponse/YXheader/refDoc/attachment/externalReference/uri) 1-1 (N)</p> <p>(XPath YARNOrdResponse/YXbody/YXitem/refDoc/attachment/externalReference/uri) 1-1 (N)</p>
@useProfile	<p>use profile to which the present document if compliant if it was agreed by th e parties. It is suggested a URI with reference to the firms or the URL of the profile.</p> <p>- base type: string,</p> <p>(XPath YARNOrdResponse/@useProfile) [Optional]</p>
@VAT	<p>VAT rate or code (DEPRECATED, use dtScheme element)</p> <p>- base type: string, cod. table: NT16</p> <p>http://www.ebiz.enea.it/moda-ml/repository/codelist/v2018-1/gc_NT16.xml</p> <p>(XPath YARNOrdResponse/YXheader/thirdParty/@VAT) [Optional]</p> <p>(XPath YARNOrdResponse/YXbody/YXitem/lineN/@VAT) [Optional]</p> <p>- nota: <i>Deprecated, prefer dtScheme when available.</i></p> <p>(XPath YARNOrdResponse/terms/allowanceCharge/@VAT) [Optional]</p> <p>(XPath YARNOrdResponse/YXbody/YXitem/thirdParty/@VAT) [Optional]</p>
@version	<p>Dictionary version from which the instance has been created</p> <p>- base type: string, cod. table: NT100</p> <p>http://www.ebiz.enea.it/moda-ml/repository/codelist/v2018-1/gc_NT100.xml</p> <p>(XPath YARNOrdResponse/@version) [Optional] [Default= 2018-1]</p>
yarnChar	<p>physical or mechanical parameter used to define a property of a yarn</p> <p>- base type: string, cod. table: T24</p> <p>http://www.ebiz.enea.it/moda-ml/repository/codelist/v2018-1/gc_T24.xml</p> <p>(XPath YARNOrdResponse/YXbody/YXitem/yarnSpecs/yarnChar) 1-1</p>
yarnCharText	<p>free text describing the physical or mechanical parameter used to define a p roperty of a yarn</p> <p>- base type: string, max length: 250,</p> <p>(XPath YARNOrdResponse/YXbody/YXitem/yarnSpecs/yarnCharText) 1-1 (U)</p>
yarnConeAngle	<p>tapering angle of the cone on which a yarn is reeled</p> <p>- base type: positiveInteger,</p> <p>(XPath YARNOrdResponse/yarnComInfo/yarnPack/yarnReel/yarnConeAngle) 0-1</p> <p>(XPath YARNOrdResponse/YXbody/YXitem/yarnComInfo/yarnPack/yarnReel/yarnConeAngle) 0-1</p>

yarnOutWrap	code specifying the type of outer wrapping or packing of a yarn - base type: string, cod. table: T33 http://www.ebiz.enea.it/moda-ml/repository/codelist/v2018-1/gc_T33.xml (XPath YARNOrdResponse/yarnComInfo/yarnPack/yarnOutWrap) 0-1 (XPath YARNOrdResponse/YXbody/YXitem/yarnComInfo/yarnPack/yarnOutWrap) 0-1
yarnOutWrapText	free text specifying the type of outer wrapping or packing of a yarn - base type: string, max length: 250, (XPath YARNOrdResponse/yarnComInfo/yarnPack/yarnOutWrapText) 0-1 (U) (XPath YARNOrdResponse/YXbody/YXitem/yarnComInfo/yarnPack/yarnOutWrapText) 0-1 (U)
yarnPay	type of payment to be applied to a yarn supply - base type: string, cod. table: T34 http://www.ebiz.enea.it/moda-ml/repository/codelist/v2018-1/gc_T34.xml (XPath YARNOrdResponse/yarnComInfo/yarnPay) 0-1 (XPath YARNOrdResponse/YXbody/YXitem/yarnComInfo/yarnPay) 0-1
yarnReelD	diameter of the bobbin used for a yarn product - base type: decimal, min inclusive: 0, fraction digits: 2, (XPath YARNOrdResponse/yarnComInfo/yarnPack/yarnReel/yarnReelD) 0-1 (XPath YARNOrdResponse/YXbody/YXitem/yarnComInfo/yarnPack/yarnReel/yarnReelD) 0-1
yarnReelH	height of the bobbin used a yarn product - base type: decimal, min inclusive: 0, fraction digits: 2, (XPath YARNOrdResponse/YXbody/YXitem/yarnComInfo/yarnPack/yarnReel/yarnReelH) 0-1 (XPath YARNOrdResponse/yarnComInfo/yarnPack/yarnReel/yarnReelH) 0-1
yarnReelQty	quantity of yarn (by weight or length) wound upon a bobbin - base type: decimal, min inclusive: 0, fraction digits: 2, (XPath YARNOrdResponse/YXbody/YXitem/yarnComInfo/yarnPack/yarnReel/yarnReelQty) 0-2 (XPath YARNOrdResponse/yarnComInfo/yarnPack/yarnReel/yarnReelQty) 0-2
yarnReelWrap	type of wrapping in which a package of yarn is wrapped - base type: string, cod. table: T32 http://www.ebiz.enea.it/moda-ml/repository/codelist/v2018-1/gc_T32.xml (XPath YARNOrdResponse/yarnComInfo/yarnPack/yarnInWrap/yarnReelWrap) 1-1 (XPath YARNOrdResponse/YXbody/YXitem/yarnComInfo/yarnPack/yarnInWrap/yarnReelWrap) 1-1
yarnTreat	information on the special treatments and finishing of a yarn product - base type: string, cod. table: T35 http://www.ebiz.enea.it/moda-ml/repository/codelist/v2018-1/gc_T35.xml (XPath YARNOrdResponse/YXbody/YXitem/yarnTreat) 0-9
yarnTreatText	free text description of the special treatments of a yarn - base type: string, max length: 250, (XPath YARNOrdResponse/YXbody/YXitem/yarnTreatText) 0-9 (N)

2.3 Suggested best practices

YARNOrdResponse/YXheader/refDoc/docID (identification number of the referenced document SINCE 2008-1 ITS USE IN THE HEADER IS DISCOURAGED (REPLACED BY msgID))

numberingOrg indicates the role that produced the document identifier (it is allowed to declare two different ones -e.g. customer and supplier - with two docID with different numberingOrg

YARNOrdResponse/YXbody/YXitem/refDoc/docID (identification number of the referenced document SINCE 2008-1 ITS USE IN THE HEADER IS DISCOURAGED (REPLACED BY msgID))

numberingOrg indicates the role that produced the document identifier (it is allowed to declare two different ones -e.g. customer and supplier - with two docID with different numberingOrg

**YARNOrdResponse/YXheader/refDoc/attachment/
externalReference/mimeCode (mime type of the external object)**

Use coding from IANA <http://www.iana.org/assignments/media-types/media-types.xml>

**YARNOrdResponse/YXbody/YXitem/refDoc/attachment/
externalReference/mimeCode (mime type of the external object)**

Use coding from IANA <http://www.iana.org/assignments/media-types/media-types.xml>

YARNOrdResponse/YXbody/YXitem/qty (net quantity of the article or object correlated, qualified by the function of the document (ordering, delivering, ..) and by the context)

this element can have two instances only if the units of measure are different

2.4 Enumeration tables

List of enumeration tables used in the XML document. You can find the corresponding codes at:
<http://www.ebiz-tcf.eu/moda-ml/imple/moda-ml-2018-1.asp?lingua=en&pag=6>

Legenda

- N: new table
- U: updated properties

NT1 - Order type
NT100 - eBIZ TCFUpstream version
NT11 - transport causal
NT12 - data source
NT16 - VAT rate or code
NT18 - message function
NT19 - currency use qualifier
NT2 - third party qualifier
NT20 - price qualifier
NT29 - format of a date
NT3 - data format
NT4 - end use
NT43 - operational code qualifier (N)
NT5 - action code
NT6 - coding system owner/issuer
NT60 - language, codes from ISO 639-1 (subset) (N)
NT7 - unit of measure (U)
T1 - terms of payment
T10 - ISO3166 - Country
T19 - fibre type
T2 - Modes of payment
T21 - type of document
T24 - yarn characteristics type
T29 - type of yarn package
T3 - terms of delivery
T30 - support of yarn package - material
T32 - yarn reel wrapping type
T33 - yarn outer packing
T34 - yarn payment type
T35 - yarn treatment type
T38 - transport conditions
T40 - type of transport means
T41 - type of Allowance or Charge
T44 - additional code type
T61 - duty or tax or fee type
T62 - duty or tax or fee category
T8 - Modes of Transport
T9 - ISO4217 - Currency

Annex A

Representative images of the principal complex elements' structure.

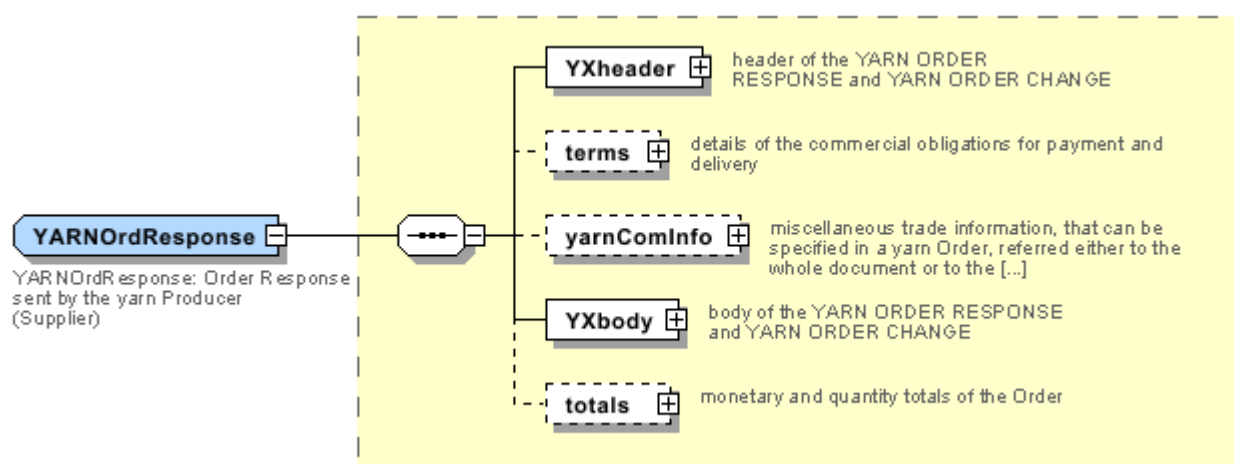
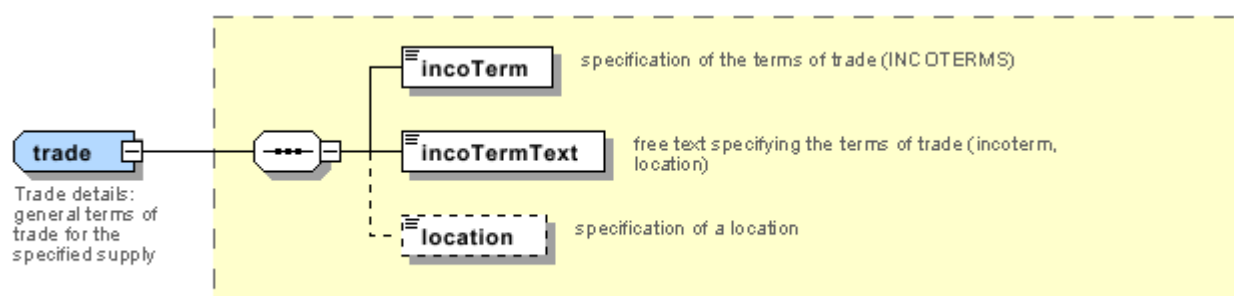
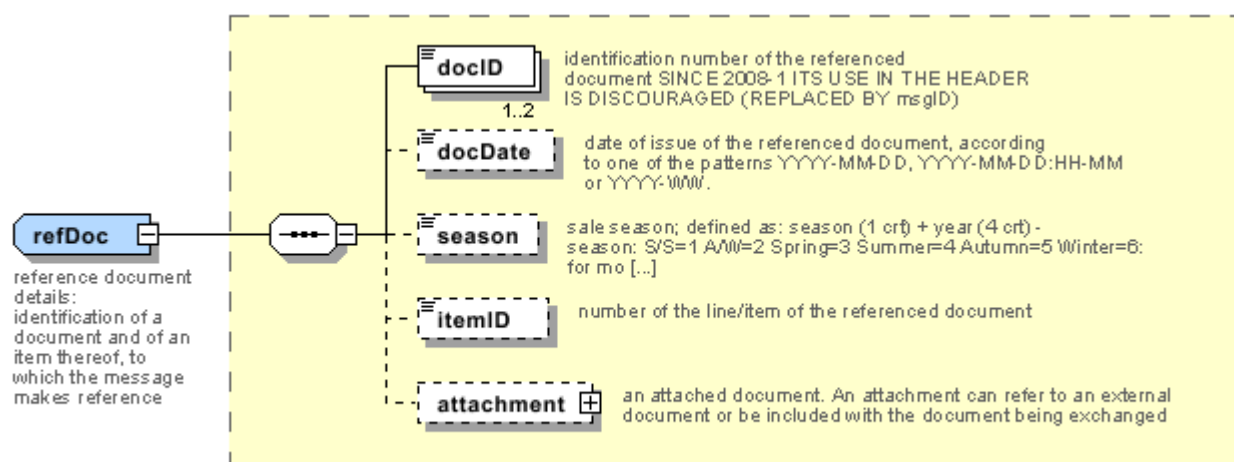

YXheader

YXheader:
header of
the YARN
ORDER
RESPONSE
and YARN
ORDER
CHANGE

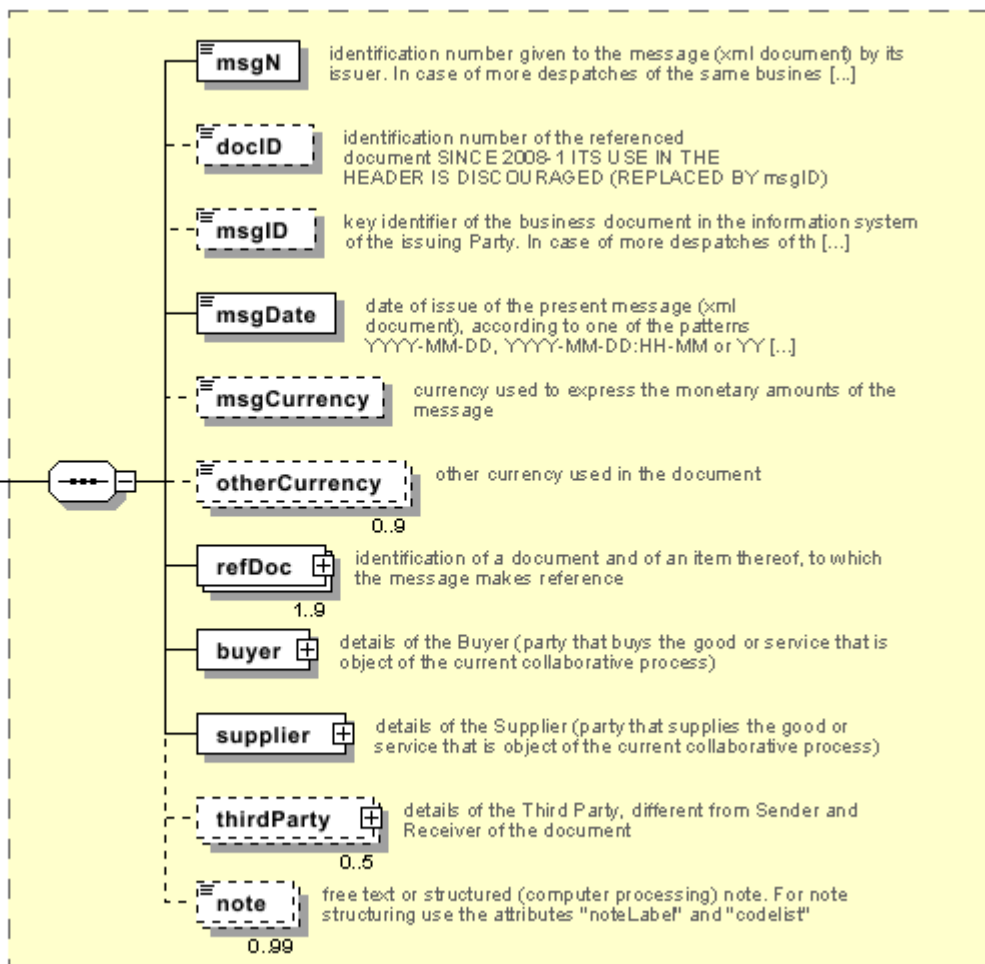

YXitem
 YXitem:
 line item
 of the
 YARN ORDER
 RESPONSE
 and YARN
 ORDER
 CHANGE

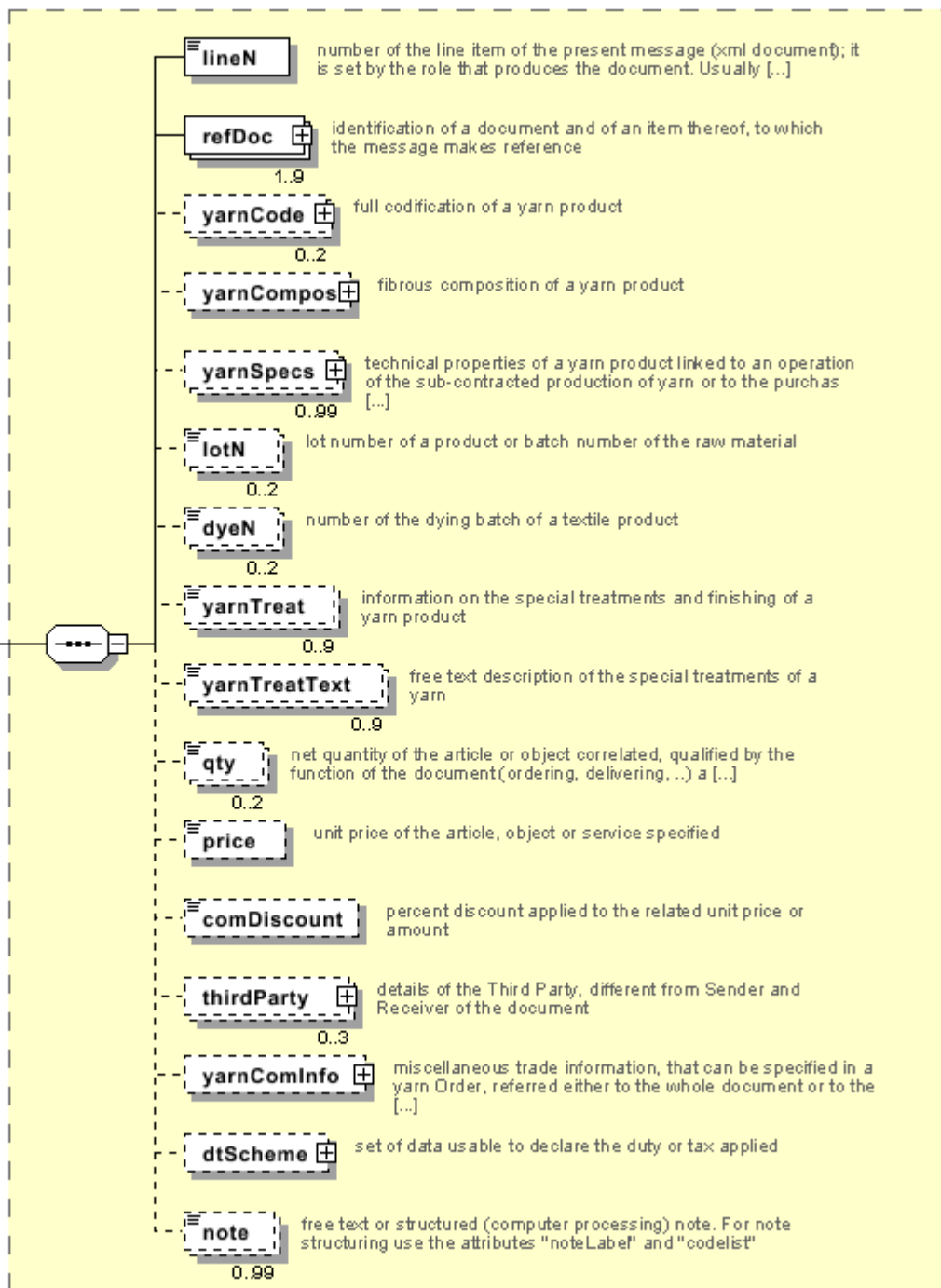

Annex B

NT1 - Order type

type of Order

Agency name: eBIZ

tabella cod.: NT1

File codes list (Generic code): http://www.ebiz.enea.it/moda-ml/repository/codelist/v2018-1/gc_NT1.xml

Code	Description	Adoption note	Version status	Date of insertion
A	blanket	the order is open without a concrete delivery of product; it establishes an amount of goods to be produced in a future	(U)	
D	call-off	orders an amount of goods to be delivered (and invoiced and produced if necessary); it is important that it is clear that this amount should be subtracted from the amount of the blanket order referred in the refDoc element	(U)	
P	reservation			
STD	standard			

NT100 - eBIZ TCFUpstream version

dictionary version

Agency name: eBIZ

tabella cod.: NT100

File codes list (Generic code): http://www.ebiz.enea.it/moda-ml/repository/codelist/v2018-1/gc_NT100.xml

Code	Description	Adoption note	Version status	Date of insertion
2013-1	v2013-1			01/07/2013
2018-1	v2018-1		(N)	04/11/2018
draft	draft		(N)	08/09/2017

NT11 - transport causal

reason for the transport

Agency name: eBIZ

tabella cod.: NT11

File codes list (Generic code): http://www.ebiz.enea.it/moda-ml/repository/codelist/v2018-1/gc_NT11.xml

Code	Description	Adoption note	Version status	Date of insertion
FOC	free of charge			
FRW	return from re-works			
FST	return from storage			
FVW	return from view			
FWK	return from works			
IST	in storage			
NWK	return non-worked			
RJC	return from rejection			
SEL	to sell			
STO	to storage			
VEW	to view			
WRK	to works			

NT12 - data source

party who has provided the data

Agency name: eBIZ

tabella cod.: NT12

File codes list (Generic code): http://www.ebiz.enea.it/moda-ml/repository/codelist/v2018-1/gc_NT12.xml

Code	Description	Adoption note	Version status	Date of insertion
AC	internal test			
CO	external test			
CV	test after steaming			

NT16 - VAT rate or code

VAT rate or code (DEPRECATED, use dtScheme element)

tabella cod.: NT16

File codes list (Generic code): http://www.ebiz.enea.it/moda-ml/repository/codelist/v2018-1/gc_NT16.xml

NT18 - message function

function performed by the present message with regards to the transmission

Agency name: eBIZ

tabella cod.: NT18

File codes list (Generic code): http://www.ebiz.enea.it/moda-ml/repository/codelist/v2018-1/gc_NT18.xml

Code	Description	Adoption note	Version status	Date of insertion
CA	delete this document			01/07/2013
CP	copy			
OR	original			
RC	re-transmission for data correction			
RT	re-transmission			

NT19 - currency use qualifier

qualification of another currency used in the document

Agency name: eBIZ

tabella cod.: NT19

File codes list (Generic code): http://www.ebiz.enea.it/moda-ml/repository/codelist/v2018-1/gc_NT19.xml

Code	Description	Adoption note	Version status	Date of insertion
CAT	pricelist currency			
INV	invoicing currency			
ORD	order currency			
PAY	payment currency			
SAL	sales currency			

NT2 - third party qualifier

Third Party role qualifier

Agency name: eBIZ

tabella cod.: NT2

File codes list (Generic code): http://www.ebiz.enea.it/moda-ml/repository/codelist/v2018-1/gc_NT2.xml

Code	Description	Adoption note	Version status	Date of insertion
AG	Sales Agent			

AU	Auditor		(N)	08/04/2019
CE	Certification authority		(N)	08/04/2019
CO	Quality Controller			
DC	Response to			
DF	Invoicee			
DI	Copy to (CC)			28/10/2014
DM	Consignee			
DP	Consignment address (Delivery Party)			
IM	Importer			
OR	Originator			10/09/2014
SC	Sub contractor		(N)	10/04/2019
SM	Service/ePlatform manager		(N)	08/04/2019
SP	Forwarder			
TX	Tax Representative			

NT20 - price qualifier

type of price with reference to discount and taxes

Agency name: eBIZ

tabella cod.: NT20

File codes list (Generic code): http://www.ebiz.enea.it/moda-ml/repository/codelist/v2018-1/gc_NT20.xml

Code	Description	Adoption note	Version status	Date of insertion
GET	gross excluding taxes			
GIT	gross including taxes			
NET	net excluding taxes			
NIT	net including taxes			

NT29 - format of a date

format used for the date

Agency name: eBIZ

tabella cod.: NT29

File codes list (Generic code): http://www.ebiz.enea.it/moda-ml/repository/codelist/v2018-1/gc_NT29.xml

Code	Description	Adoption note	Version status	Date of insertion
------	-------------	---------------	----------------	-------------------

D	YYYY-MM-DD			
M	YYYY-MM-DD:HH-MM			
W	YYYY-WW			

NT3 - data format

format of a string according to a customized User rule (local rule)

Agency name: eBIZ

tabella cod.: NT3

File codes list (Generic code): http://www.ebiz.enea.it/moda-ml/repository/codelist/v2018-1/gc_NT3.xml

Code	Description	Adoption note	Version status	Date of insertion
EN4	GS1-GLN			01/07/2013
MD	mutually agreed			

NT4 - end use

specifies the final use of the product

Agency name: eBIZ

tabella cod.: NT4

File codes list (Generic code): http://www.ebiz.enea.it/moda-ml/repository/codelist/v2018-1/gc_NT4.xml

Code	Description	Adoption note	Version status	Date of insertion
PC	test piece			
PR	production			
SA	Sample		(N)	10/09/2014
SC	samples card			
TI	patch			
TP	(test cut)			

NT43 - operational code qualifier (N)

Agency name: eBIZ

tabella cod.: NT43

File codes list (Generic code): http://www.ebiz.enea.it/moda-ml/repository/codelist/v2018-1/gc_NT43.xml

Code	Description	Adoption note	Version status	Date of insertion
1	event		(N)	08/09/2017
2	sales channel		(N)	08/09/2017
3	goods management type		(N)	08/09/2017
4	special initiative		(N)	08/09/2017

NT5 - action code

action performed by the present line upon the referenced document line

Agency name: eBIZ

tabella cod.: NT5

File codes list (Generic code): http://www.ebiz.enea.it/moda-ml/repository/codelist/v2018-1/gc_NT5.xml

Code	Description	Adoption note	Version status	Date of insertion
A	CANCELLED			
C	CONFIRMED			
N	NEW ORDER LINE (created by an order change)			
R	PROVISIONAL CONFIRMATION			
S	DEFINITIVE CONFIRMATION			
SA	suspension accepted			
SN	suspension not accepted			
SR	suspension request			
V	AMENDED			

NT6 - coding system owner/issuer

code specifying the organisation who has created or owns the coding or numbering system

Agency name: eBIZ

tabella cod.: NT6

File codes list (Generic code): http://www.ebiz.enea.it/moda-ml/repository/codelist/v2018-1/gc_NT6.xml

Code	Description	Adoption note	Version status	Date of insertion
CL	Customer/buyer			
CO	Quality Controller			
EB	eBIZ	replaces 'ML'	(N)	18/03/2019

EN	GS1 (ex-EAN International)			
ES	e-Stockflow			
FO	Supplier			
GS	GS1			01/07/2013
MF	VAT identifier		(U)	
ML	Moda-ML	DEPRECATED	(U)	
SP	Service Provider			

NT60 - language, codes from ISO 639-1 (subset) (N)

Agency name: eBIZ / ISO

tabella cod.: NT60

File codes list (Generic code): http://www.ebiz.enea.it/moda-ml/repository/codelist/v2018-1/gc_NT60.xml

Code	Description	Adoption note	Version status	Date of insertion
af	Afrikaans		(N)	31/01/2019
ar	Arabic		(N)	31/01/2019
be	Belarusian		(N)	31/01/2019
bg	Bulgarian		(N)	31/01/2019
bn	Bengali		(N)	31/01/2019
bo	Tibetan		(N)	31/01/2019
bs	Bosnian		(N)	31/01/2019
ca	Catalan, Valencian		(N)	31/01/2019
cs	Czech		(N)	31/01/2019
da	Danish		(N)	31/01/2019
de	German		(N)	31/01/2019
el	Greek, Modern (1453-)		(N)	31/01/2019
en	English		(N)	31/01/2019
eo	Esperanto		(N)	31/01/2019
es	Spanish, Castilian		(N)	31/01/2019
et	Estonian		(N)	31/01/2019
eu	Basque		(N)	31/01/2019
F	Female		(N)	15/04/2019
fa	Persian		(N)	31/01/2019
fi	Finnish		(N)	31/01/2019
fr	French		(N)	31/01/2019

ga	Irish		(N)	31/01/2019
gd	Gaelic, Scottish Gaelic		(N)	31/01/2019
gn	Guarani		(N)	31/01/2019
he	Hebrew		(N)	31/01/2019
hr	Croatian		(N)	31/01/2019
ht	Haitian, Haitian Creole		(N)	31/01/2019
hu	Hungarian		(N)	31/01/2019
hy	Armenian		(N)	31/01/2019
ia	Interlingua (International Auxiliary Language Association)		(N)	31/01/2019
id	Indonesian		(N)	31/01/2019
is	Icelandic		(N)	31/01/2019
it	Italian		(N)	31/01/2019
ja	Japanese		(N)	31/01/2019
jv	Javanese		(N)	31/01/2019
ka	Georgian		(N)	31/01/2019
km	Central Khmer		(N)	31/01/2019
ko	Korean		(N)	31/01/2019
ku	Kurdish		(N)	31/01/2019
lb	Luxembourgish, Letzeburgesch		(N)	31/01/2019
lo	Lao		(N)	31/01/2019
lt	Lithuanian		(N)	31/01/2019
lv	Latvian		(N)	31/01/2019
mg	Malagasy		(N)	31/01/2019
mk	Macedonian		(N)	31/01/2019
mn	Mongolian		(N)	31/01/2019
mt	Maltese		(N)	31/01/2019
nl	Dutch, Flemish		(N)	31/01/2019
no	Norwegian		(N)	31/01/2019
pl	Polish		(N)	31/01/2019
pt	Portuguese		(N)	31/01/2019
ro	Romanian, Moldavian, Moldovan		(N)	31/01/2019
ru	Russian		(N)	31/01/2019
se	Northern Sami		(N)	31/01/2019
sk	Slovak		(N)	31/01/2019
sl	Slovenian		(N)	31/01/2019

sm	Samoan		(N)	31/01/2019
so	Somali		(N)	31/01/2019
sq	Albanian		(N)	31/01/2019
sr	Serbian		(N)	31/01/2019
sv	Swedish		(N)	31/01/2019
sw	Swahili		(N)	31/01/2019
ta	Tamil		(N)	31/01/2019
th	Thai		(N)	31/01/2019
tr	Turkish		(N)	31/01/2019
uk	Ukrainian		(N)	31/01/2019
ur	Urdu		(N)	31/01/2019
uz	Uzbek		(N)	31/01/2019
vi	Vietnamese		(N)	31/01/2019
zh	Chinese		(N)	31/01/2019

NT7 - unit of measure (U)

specification of the unit of measure, it is a sub set of table Unit of Measure Code - UN/ECE REC 20 delivered by United Nations Economic Commission for Europe (UN/ECE)

Agency name: eBIZ / UN/ECE

tabella cod.: NT7

File codes list (Generic code): http://www.ebiz.enea.it/moda-ml/repository/codelist/v2018-1/gc_NT7.xml

Other link: <http://docs.oasis-open.org/ubl/os-UBL-2.1/cl/gc/default/UnitOfMeasureCode-2.1.gc#>

Code	Description	Adoption note	Version status	Date of insertion
CMK	square centimetre		(N)	20/12/2017
CMQ	cubic centimetre		(N)	20/12/2017
CMT	centimetre			
CNE	centiNewton			
CO2TON	ton of CO2		(N)	10/09/2014
COUPLES	couples			
DMQ	cubic decimetre			
E37	pixel		(N)	11/04/2018
GRM	gram			
HUR	hour			
INH	inch			

KGM	kilogram			
KMT	kilometer			
KWH	kilowatthours		(N)	10/09/2014
LBR	pound			
MIN	minute			
MMK	square millimetre		(N)	20/12/2017
MTK	square metre		(N)	20/12/2017
MTQ	cubic metre			
MTR	metre			
NMB	numero			
ONZ	ounce			
P1	percent			
PPM	parts per milion			
PZ	piece		(U)	
RPM	rounds per metre			
YRD	yard			

T1 - terms of payment

code specifying the terms or time by which the payment must be done

Agency name: eBIZ

tabella cod.: T1

File codes list (Generic code): http://www.ebiz.enea.it/moda-ml/repository/codelist/v2018-1/gc_T1.xml

Code	Description	Adoption note	Version status	Date of insertion
ANTICIP	PAYMENT IN ADVANCE			
BLCOLLECT/120D	BILL OF LADING 120 DD			
BLCOLLECT/30D	BILL OF LADING 30 DD			
BLCOLLECT/60D	BILL OF LADING 60 DD			
BLCOLLECT/90D	BILL OF LADING 90 DD			
CASH	PAYMENT ON DELIVERY			
CASHINV	PAYMENT ON RECEIPT OF INVOICE			
CREDOC/0D	DOCUMENTARY CREDIT FOR PAYM. AT SIGHT			
CREDOC/120	DOCUMENTARY CREDIT FOR PAYM. AT 120 DD			

CREDOC/150	DOCUMENTARY CREDIT FOR PAYM. AT 150 DD			
CREDOC/180	DOCUMENTARY CREDIT FOR PAYM. AT 180 DD			
CREDOC/30D	DOCUMENTARY CREDIT FOR PAYM. AT 30 DD			
CREDOC/45D	DOCUMENTARY CREDIT FOR PAYM. AT 45 DD			
CREDOC/60	DOCUMENTARY CREDIT FOR PAYM. AT 60 DD			
CREDOC/90	DOCUMENTARY CREDIT FOR PAYM. AT 90 DD			
DEL/10	PAYMENT AT 10 DD AFTER DELIVERY			
DOCOLLECT/120D	DOCUMENTARY COLLECTION AT 120 DD			
DOCOLLECT/30D	DOCUMENTARY COLLECTION AT 30 DD			
DOCOLLECT/60D	DOCUMENTARY COLLECTION AT 60 DD			
DOCOLLECT/90D	DOCUMENTARY COLLECTION AT 90 DD			
INV/120D	PAYMENT AT 120 DD AFTER RECEIPT OF INVOICE			
INV/150D	PAYMENT AT 150 DD AFTER RECEIPT OF INVOICE			
INV/180D	PAYMENT AT 180 DD AFTER RECEIPT OF INVOICE			
INV/30D	PAYMENT AT 30 DD AFTER RECEIPT OF INVOICE			
INV/45D	PAYMENT AT 45 DD AFTER RECEIPT OF INVOICE			
INV/60D	PAYMENT AT 60 DD AFTER RECEIPT OF INVOICE			
INV/90D	PAYMENT AT 90 DD AFTER RECEIPT OF INVOICE			
INVULTIMO	PAYMENT AT END MONTH RECEIPT INVOICE			
INVULTIMO/10D	PAYMENT 10 DD AFTER END MONTH RECEIPT INVOICE			
INVULTIMO/120D	PAYMENT 120 DD AFTER END MONTH RECEIPT INVOICE			
INVULTIMO/150D	PAYMENT 150 DD AFTER END MONTH RECEIPT INVOICE			
INVULTIMO/180D	PAYMENT 180 DD AFTER END MONTH RECEIPT INVOICE			
INVULTIMO/240D	PAYMENT 240 DD AFTER END MONTH RECEIPT INVOICE			
INVULTIMO/30D	PAYMENT 30 DD AFTER END MONTH RECEIPT INVOICE			
INVULTIMO/45D	PAYMENT 45 DD AFTER END MONTH RECEIPT INVOICE			
INVULTIMO/60D	PAYMENT 60 DD AFTER END MONTH RECEIPT INVOICE			
INVULTIMO/90D	PAYMENT 90 DD AFTER END MONTH RECEIPT INVOICE			

NOPAY	WITHOUT PAYMENT			
RECREDOC/0D	IRREVOC. DOCUMENTARY CREDIT FOR PAYM. AT SIGHT			
RECREDOC/120D	IRREVOC. DOCUMENTARY CREDIT FOR PAYM. AT 120 DD			
RECREDOC/150D	IRREVOC. DOCUMENTARY CREDIT FOR PAYM. AT 150 DD			
RECREDOC/180D	IRREVOC. DOCUMENTARY CREDIT FOR PAYM. AT 180 DD			
RECREDOC/30D	IRREVOC. DOCUMENTARY CREDIT FOR PAYM. AT 30 DD			
RECREDOC/45D	IRREVOC. DOCUMENTARY CREDIT FOR PAYM. AT 45 DD			
RECREDOC/60D	IRREVOC. DOCUMENTARY CREDIT FOR PAYM. AT 60 DD			
RECREDOC/90D	IRREVOC. DOCUMENTARY CREDIT FOR PAYM. AT 90 DD			
ULTIMO	PAYMENT BY END MONTH OF DELIVERY			
ULTIMO/10	PAYMENT AT 10 DD AFTER END MONTH OF DELIVERY			

T10 - ISO3166 - Country

code of the nation

Agency name: ISO

tabella cod.: T10

File codes list (Generic code): http://www.ebiz.enea.it/moda-ml/repository/codelist/v2018-1/gc_T10.xml

Table not printed: there are 239 elements, more than the maximum specified for printing: 99.

T19 - fibre type

type of fibre used in a textile product

Agency name: eBIZ

tabella cod.: T19

File codes list (Generic code): http://www.ebiz.enea.it/moda-ml/repository/codelist/v2018-1/gc_T19.xml

Code	Description	Adoption note	Version status	Date of insertion
AB	abaca			20/08/2018
AC	acetate			

AF	other fibres			
AG	alginic fibre			
AL	alfa			20/08/2018
CA	hemp			
CC	coir (coconut)			20/08/2018
CL	chlorofibre			
CO	cotton			
CU	cuprous			
EA	elastan			
EL	Elastodiene			20/08/2018
FL	fluorofibre			
GI	broom			20/08/2018
GL	textile glass			
HA	hair			20/08/2018
HE	henequen			20/08/2018
HL	mixed linen			
HL	cotton linen union			20/08/2018
JU	jute			
KE	kenaf			20/08/2018
KP	kapoc			20/08/2018
LI	linen			
LY	lyocell			20/08/2018
MA	modacrylic			
MD	modal			
ME	metallized			
MG	maguey			20/08/2018
PA	polyamide			
PB	polyureic			
PC	acrylic			
PE	polyethylene			
PI	paper			20/08/2018
PL	polyester			
PM	polyimide			
PP	polypropylene			
PR	proteic			

PU	polyurethane			
RA	mamie			20/08/2018
SE	silk			
SI	sisal			20/08/2018
SN	sun			20/08/2018
TA	triacetate			
TR	textile residues or unspecified composition			20/08/2018
TV	trivinyll			
VI	viscose			
VY	vinylal			
WA	angora			
WB	beaver			20/08/2018
WC	cashgora			
WG	vicuna			
WK	camel			
WL	llama			
WM	mohair			
WN	lapin			20/08/2018
WO	wool			
WP	alpaca			
WS	cashmere			
WT	Oteer			20/08/2018
WU	guanaco			
WV	virgin wool			
WY	yack			

T2 - Modes of payment

way or means of payment

Agency name: eBIZ

tabella cod.: T2

File codes list (Generic code): http://www.ebiz.enea.it/moda-ml/repository/codelist/v2018-1/gc_T2.xml

Code	Description	Adoption note	Version status	Date of insertion
BB	bank transfer			
IA	collection through Agent			

IS	collection through Forwarder			
RB	bank receipt			
RD	remittance			
SW	bank SWIFT			
TR	bank draft			

T21 - type of document

type or class to which the referenced document belongs

Agency name: eBIZ

tabella cod.: T21

File codes list (Generic code): http://www.ebiz.enea.it/moda-ml/repository/codelist/v2018-1/gc_T21.xml

Code	Description	Adoption note	Version status	Date of insertion
BOR	blanket order		(N)	01/02/2018
CAT	Price catalogue - tech sheet			
CEO	Certificate of origin		(N)	13/04/2018
CER	Certificate		(N)	13/04/2018
COC	colour card			
CRN	Credit note			08/09/2017
CTO	Checking order			01/07/2013
CTR	Contract		(U)	
CXF	CxF3 file			01/07/2013
DAD	Darn order			
DDT	ddt			
DEA	Despatch advise			
DER	Despatch request			
DR	Document Request			02/12/2014
FOR	Forecast			02/12/2014
GSO	Garment stock offer			
GSX	Garment stock offer change			
INV	Invoice			
KCC	Knitting-Clothing Commission Order			02/12/2014
KCI	Garment in Work Inventory Report			02/12/2014
M2M	Made to Measure Production Order			02/12/2014
MAS	Master marker			

MCI	Visual merchandising instruction		(N)	13/04/2018
OCH	Order change			
OFF	Offer			
ORD	Purchase order			
ORP	Order response			
OSR	order status request			
OSS	Offer status			02/12/2014
OST	Order status			
OUR	our reference			
QR	Quality Report			02/12/2014
RAI	Raw Material in Work Inventory Report			02/12/2014
RDC	Raw dyeing commission order			
RDH	Raw dyeing order change			
RDR	Raw dyeing order response			
REA	Receiving advise			
REQ	Request for Offer			
RET	Return			02/12/2014
RSC	Spinning commission order			
RSH	Spinning order change			
RSR	Spinning order response			
SCL	process sheet			
TFC	Textile dyeing-finishing commission order			
TFX	Textile Dyeing-Finishing Order Change			02/12/2014
TPC	Textile printing commission order			
TPX	Textile Printing Order Change			02/12/2014
TWI	Textile in work inventory			
VMI	visual merchandising instructions		(N)	01/02/2018
WAC	Warping commission order			
WEC	Weaving commission order			
YDC	Yarn dyeing commission order			
YDH	Yarn dyeing order change			
YDR	Yarn dyeing order response			
YTC	Twisting commission order			
YWI	Yarn in work inventory			

T24 - yarn characteristics type

physical or mechanical parameter used to define a property of a yarn

Agency name: eBIZ

tabella cod.: T24

File codes list (Generic code): http://www.ebiz.enea.it/moda-ml/repository/codelist/v2018-1/gc_T24.xml

Code	Description	Adoption note	Version status	Date of insertion
ALL	elongation			
AMIN	minimum yarn elongation			
CV	CV			
DE	delta E			
NFIN	number of cases diameter less than X%			
NGRO	number of cases diameter greater than X%			
NOD	standard nub			
NOS	Splicer nub			
PLH	H hairiness			
PLL	pilling			
RES	tensile strength			
RMIN	minimum tensile strength			
RTR	shrinkage			
SLA	fastness to light (ISO 105-B02)			
SLB	fastness to water washing (ISO 105-C06)			
SLC	fastness to dry washing (ISO 105-D01)			
SLD	fastness to water drop (ISO 105-E07)			
SLW	fastness to water (ISO 105-E01)			
SLX	fastness to Xeno light (ISO 105-E01)			
STW	S-twist			
TIN	english count			
TMT	metric count			
TTX	tex count			
ZTW	Z-twist			

T29 - type of yarn package

type of package (roll-up) used for a yarn product

Agency name: eBIZ

tabella cod.: T29

File codes list (Generic code): http://www.ebiz.enea.it/moda-ml/repository/codelist/v2018-1/gc_T29.xml

Code	Description	Adoption note	Version status	Date of insertion
CIL	bobbin			
CON	cone			
HNK	hank, skein			01/07/2013
MUF	muff, cake			01/07/2013
SPL	spool			
TUB	tube			
XCO	supercone			

T3 - terms of delivery

specification of the terms of trade (INCOTERMS)

Agency name: Incoterms

tabella cod.: T3

File codes list (Generic code): http://www.ebiz.enea.it/moda-ml/repository/codelist/v2018-1/gc_T3.xml

Code	Description	Adoption note	Version status	Date of insertion
CFR	COST AND FREIGHT (named port of destination)			
CIF	COST, INSURANCE AND FREIGHT (named port of destination)			
CIP	CARRIAGE AND INSURANCE PAID (named place of destination)			
CPA	CARRIAGE PAID (named place of destination)			
DAF	DELIVERED AT FRONTIER (named place)	according to Incoterms® 2010 it is obsolete		08/12/2017
DAP	Delivered at Place of destination (named place of destination)	according to Incoterms® 2010		08/12/2017
DAT	Delivered at Terminal (named place of destination)	according to Incoterms® 2010		08/12/2017
DDP	DELIVERED DUTY PAID (named place of destination)			

DD U	DELIVERED DUTY UNPAID (named place of destination)	according to Incoterms® 2010 it is obsolete, use DAP		08/12/2017
DE Q	DELIVERED EX-QUAY (named port of destination)	according to Incoterms® 2010 it is obsolete		08/12/2017
DE S	DELIVERED EX-SHIP (named port of destination)	according to Incoterms® 2010 it is obsolete		08/12/2017
EX W	EX WORKS (named place)			
FA S	FREE ALONGSIDE SHIP (named port of shipment)			
FC A	FREE CARRIER (named place)			
FO B	FREE ON BOARD (named port of shipment)			

T30 - support of yarn package - material

type of material of which a package for yarn is made

Agency name: eBIZ

tabella cod.: T30

File codes list (Generic code): http://www.ebiz.enea.it/moda-ml/repository/codelist/v2018-1/gc_T30.xml

Code	Description	Adoption note	Version status	Date of insertion
CA	cartoon			
DY	for soft package dyeing			
MT	metallic			01/07/2013
PL	plastic			

T32 - yarn reel wrapping type

type of wrapping in which a package of yarn is wrapped

Agency name: eBIZ

tabella cod.: T32

File codes list (Generic code): http://www.ebiz.enea.it/moda-ml/repository/codelist/v2018-1/gc_T32.xml

Code	Description	Adoption note	Version status	Date of insertion
XA	without bag			
XB	paper bag			01/07/2013
XD	plastic film bag			

T33 - yarn outer packing

code specifying the type of outer wrapping or packing of a yarn

Agency name: eBIZ

tabella cod.: T33

File codes list (Generic code): http://www.ebiz.enea.it/moda-ml/repository/codelist/v2018-1/gc_T33.xml

Code	Description	Adoption note	Version status	Date of insertion
00				
CB	cartoon box			
CC	cartoon box 18 reels			
CD	cartoon box 36 reels			
XD	plastic film			

T34 - yarn payment type

type of payment to be applied to a yarn supply

Agency name: eBIZ

tabella cod.: T34

File codes list (Generic code): http://www.ebiz.enea.it/moda-ml/repository/codelist/v2018-1/gc_T34.xml

Code	Description	Adoption note	Version status	Date of insertion
CND	conditioned			
NET	net			
NTT	net-net			

T35 - yarn treatment type

informations on the special treatments and finishing of a yarn product

Agency name: eBIZ

tabella cod.: T35

File codes list (Generic code): http://www.ebiz.enea.it/moda-ml/repository/codelist/v2018-1/gc_T35.xml

Code	Description	Adoption note	Version status	Date of insertion
00				

T38 - transport conditions

special condition of transport or special service requested to the Forwarder

tabella cod.: T38

File codes list (Generic code): http://www.ebiz.enea.it/moda-ml/repository/codelist/v2018-1/gc_T38.xml

Code	Description	Adoption note	Version status	Date of insertion
ACC	arrange customs clearance			
CAL	Carrier loads			
CAU	Carrier unloads			
CMR	CMR carnet			
FFN	freight forwarders national conditions			
FLD	special agreement for full loading			
NCC	do not arrange customs clearance			
PPB	packaging paid by Buyer			
PPS	packaging paid by Supplier			
PRO	proof of delivery			
RFR	return container free			
RPC	return container paid by Customer			
RPS	return container paid by Supplier			
SHL	Shipper loads			
SHU	Consignee unloads			

T40 - type of transport means

means of transport, in general or referred to a specific leg

Agency name: eBIZ

tabella cod.: T40

File codes list (Generic code): http://www.ebiz.enea.it/moda-ml/repository/codelist/v2018-1/gc_T40.xml

Code	Description	Adoption note	Version status	Date of insertion
AIR	aircraft			
SHP	ship			
TRU	truck			
VAN	van			

T41 - type of Allowance or Charge

coded specification of an Allowance or Charge (elaborated from UNECE 4465)

Agency name: eBIZ

tabella cod.: T41

File codes list (Generic code): http://www.ebiz.enea.it/moda-ml/repository/codelist/v2018-1/gc_T41.xml

Code	Description	Adoption note	Version status	Date of insertion
1	Agreed settlement		(N)	19/08/2018
10	Costs for draft		(N)	19/08/2018
11	Bank charges	DEPRECATED, use CBK	(N)	19/08/2018
12	Agent commission		(N)	19/08/2018
14	Wrong delivery		(N)	19/08/2018
15	Goods returned to agent		(N)	19/08/2018
16	Goods partly returned		(N)	19/08/2018
17	Transport damage		(N)	19/08/2018
19	Trade discount		(N)	19/08/2018
2	Below specification goods		(N)	19/08/2018
20	Deduction for late delivery	DEPRECATED, use CWB	(N)	19/08/2018
21	Advertising costs		(N)	19/08/2018
22	Customs duties		(N)	19/08/2018
23	Telephone and postal costs		(N)	19/08/2018
24	Repair costs		(N)	19/08/2018
25	Attorney fees		(N)	19/08/2018

26	Taxes		(N)	19/08/2018
3	Damaged goods		(N)	19/08/2018
30	Direct payment to seller		(N)	19/08/2018
32	Goods not delivered		(N)	19/08/2018
33	Late delivery		(N)	19/08/2018
35	Goods returned		(N)	19/08/2018
36	Invoice not received		(N)	19/08/2018
37	Credit note to debtor/not to us		(N)	19/08/2018
38	Deducted bonus		(N)	19/08/2018
39	Deducted discount		(N)	19/08/2018
4	Short delivery		(N)	19/08/2018
40	Deducted freight costs		(N)	19/08/2018
41	Deduction against other invoices		(N)	19/08/2018
42	Credit balance(s)		(N)	19/08/2018
45	Debit note to seller		(N)	19/08/2018
46	Discount beyond terms		(N)	19/08/2018
48	Allowance/charge error		(N)	19/08/2018
49	Substitute product		(N)	19/08/2018
50	Terms of sale error		(N)	19/08/2018
52	Wrong invoice		(N)	19/08/2018
53	Duplicate invoice		(N)	19/08/2018
54	Weight error		(N)	19/08/2018

55	Additional charge not authorized		(N)	19/08/2018
56	Incorrect discount		(N)	19/08/2018
57	Price change		(N)	19/08/2018
58	Variation		(N)	19/08/2018
59	Chargeback		(N)	19/08/2018
65	Settlement to agent		(N)	19/08/2018
66	Cash discount		(N)	19/08/2018
7	Payment on account		(N)	19/08/2018
70	Wrong monetary amount resulting from incorrect free goods quantity		(N)	19/08/2018
72	Temporary special promotion		(N)	19/08/2018
73	Difference in tax rate		(N)	19/08/2018
74	Quantity discount		(N)	19/08/2018
75	Promotion discount		(N)	19/08/2018
76	Cancellation deadline passed		(N)	19/08/2018
77	Pricing discount		(N)	19/08/2018
78	Volume discount		(N)	19/08/2018
79	Sundry discount		(N)	19/08/2018
8	Returnable container charge included		(N)	19/08/2018
9	Invoice error		(N)	19/08/2018
AWA	bonus for works ahead of schedule			
CBK	bank charges			
CCR	servizio di corriere			
CIN	insurance			

CLB	labelling			
CPK	packing			
CSP	special packing			
CW B	penalty for works behind schedule			

T44 - additional code type

qualifier of the additional coding of a product

Agency name: eBIZ

tabella cod.: T44

File codes list (Generic code): http://www.ebiz.enea.it/moda-ml/repository/codelist/v2018-1/gc_T44.xml

Code	Description	Adoption note	Version status	Date of insertion
CC	colour card			
CL	sales collection			
CO	company identification code		(N)	08/09/2017
DY	dye number			
LT	lot number			
MDI	Made in			08/09/2017
MS	manufacturing state			
PKG	packaging			09/09/2014
PL	product line			
RGB	RGB value			
SE	selvedge code			

T61 - duty or tax or fee type

duty or tax or fee type

Agency name: eBIZ

tabella cod.: T61

File codes list (Generic code): http://www.ebiz.enea.it/moda-ml/repository/codelist/v2018-1/gc_T61.xml

Code	Description	Adoption note	Version status	Date of insertion
BOL	stamp duty			01/07/2013
CUD	customs duty			01/07/2013

ENV	environmental tax			01/07/2013
FRE	no tax			01/07/2013
OTH	other tax charges			01/07/2013
VAT	value added tax			01/07/2013

T62 - duty or tax or fee category

duty or tax or fee category

Agency name: eBIZ

tabella cod.: T62

File codes list (Generic code): http://www.ebiz.enea.it/moda-ml/repository/codelist/v2018-1/gc_T62.xml

Code	Description	Adoption note	Version status	Date of insertion
AA	lower than standard rate			01/07/2013
E	tax not applicable			01/07/2013
H	higher than standard rate			01/07/2013
O	outside scope of tax			01/07/2013
S	standard rate			01/07/2013
Z	zero rate goods			01/07/2013

T8 - Modes of Transport

way of transport, in general or referred to the specified leg

Agency name: eBIZ

tabella cod.: T8

File codes list (Generic code): http://www.ebiz.enea.it/moda-ml/repository/codelist/v2018-1/gc_T8.xml

Code	Description	Adoption note	Version status	Date of insertion
1	MARITIME TRANSPORT			
10	Courier			01/07/2013
2	RAIL TRANSPORT			
3	ROAD TRANSPORT			
4	AIR TRANSPORT			
5	MAIL			
6	AIR + SHIP TRANSPORT			
8	INLAND WATER TRANSPORT			

9	MODE UNKNOWN			
---	--------------	--	--	--

T9 - ISO4217 - Currency

currency code

Agency name: ISO

tabella cod.: T9

File codes list (Generic code): http://www.ebiz.enea.it/moda-ml/repository/codelist/v2018-1/gc_T9.xml

Table not printed: there are 205 elements, more than the maximum specified for printing: 99.

Annex C

New or changed elements towards previous version

Changes or added elements (changes in description excluded; changes in aggregation notes and best practice included): 130

Test Type	Tag	Status	Item type	Changes related to
Attribute	AC_amount	NEW	AC amount	Has NEW attribute: data currency
Element(E)	AC_categoryText	UPDATED	AC category text	Property: Length_Max Old value: 70 New value: 250
Attribute	additionalIdentifier	NEW	Additional Party Identifier	Has NEW attribute: numbering organisation code
Attribute	additionalIdentifier	NEW	Additional Party Identifier	Has NEW attribute: id Qualifier
Element(I)	additionalIdentifier	NEW	Additional Party Identifier	
Attribute	allowanceCharge	NEW	Allowance and Charge	Has NEW attribute: is Charge
Attribute	allowanceCharge	NEW	Allowance and Charge	Has NEW attribute: maximum quantity
Attribute	allowanceCharge	NEW	Allowance and Charge	Has NEW attribute: minimum quantity
Attribute	allowanceCharge	NEW	Allowance and Charge	Has NEW attribute: data currency
Attribute	allowanceCharge	NEW	Allowance and Charge	Has NEW attribute: unit of measure code
Element(E)	art	UPDATED	article identifier	Property: Length_Max Old value: 25 New value: 80
Attribute	art	UPDATED	article identifier	Its attribute: code list reference Property: Aggregation Note_English Old value: <i>this attribute should be ALTERNATIVE to the others</i> New value: <i>at least one out of this attribute and "numberingOrg" should be set</i>

Element(l)	attachment	NEW	attachment	
Child	attachment	NEW	attachment	Has NEW child of: file name
Child	attachment	NEW	attachment	Has NEW child of: external reference
Child	attachment	NEW	attachment	Has NEW child of: binary object
Attribute	binaryObject	NEW	binary object	Has NEW attribute: encoding
Attribute	binaryObject	NEW	binary object	Has NEW attribute: mime
Attribute	binaryObject	NEW	binary object	Has NEW attribute: format
Attribute	binaryObject	NEW	binary object	Has NEW attribute: character set
Element(l)	binaryObject	NEW	binary object	
Attribute	brand	NEW	Brand	Has NEW attribute: code list version
Element(l)	brand	NEW	Brand	
Attribute	brand	NEW	Brand	Has NEW attribute: numbering organisation code
Attribute	brand	NEW	Brand	Has NEW attribute: code list reference
Attribute	brand	NEW	Brand	Has NEW attribute: code list name
Child	buyer	NEW	Buyer (*)	Has NEW child of: Party identifier
Child	buyer	NEW	Buyer (*)	Has NEW child of: Additional Party Identifier
Attribute	buyer	NEW	Buyer (*)	Has NEW attribute: sender Party qualifier
Element(l)	characterSetCode	NEW	character set code	
Element(l)	characterSet	NEW	character set	
Element(l)	codeQualifier	NEW	code qualifier	
Element(E)	deliveryPlace	UPDATE	delivery place	Property: Length_Max Old value: 40 New value: 250
Attribute	description	NEW	description	Has NEW attribute: In

Element(E)	description	UPDATED	description	Property: Length_Max Old value: 70 New value: 250
Attribute	despatchDate	NEW	despatch date	Has NEW attribute: date format
Element(l)	despatchDate	NEW	despatch date	
Element(l)	despatchPlace	NEW	despatch place	
Element(E)	email	UPDATED	e-mail	Property: Length_Max Old value: 80 New value: 250
Element(l)	encodingCode	NEW	encoding code	
Element(l)	encoding	NEW	encoding	
Element(l)	exchangeRate	NEW	exchange rate	
Child	externalReference	NEW	external reference	Has NEW child of: uri
Child	externalReference	NEW	external reference	Has NEW child of: format code
Child	externalReference	NEW	external reference	Has NEW child of: character set code
Child	externalReference	NEW	external reference	Has NEW child of: mime code
Child	externalReference	NEW	external reference	Has NEW child of: encoding code
Element(l)	externalReference	NEW	external reference	
Attribute	fileName	NEW	file name	Has NEW attribute: numbering organisation code
Element(l)	fileName	NEW	file name	
Element(l)	formatCode	NEW	format code	
Element(l)	format	NEW	format	
Attribute	note	UPDATED	general note	Its attribute: numbering organisation code Property: Aggregation Note_English

				Old value: New value: <i>must be used to specify the organization that created the list of codes used in "noteLabel"</i>
Attrib	goodsAmount	NEW	goods total amount	Has NEW attribute: data currency
Elem(l)	idQualifier	NEW	id Qualifier	
Elem(l)	isCharge	NEW	is Charge	
Elem(l)	isURL	NEW	is URL	
Elem(E)	legalName	UPDATED	Legal name	Property: Length_Max Old value: 80 New value: 250
Elem(E)	itemID	UPDATED	line item number	Property: Length_Max Old value: 6 New value: 40
Attrib	lineN	UPDATED	line number	Its attribute: VAT rate Property: Aggregation Note_English Old value: New value: <i>Deprecated, prefer dtScheme when available.</i>
Elem(l)	ln	NEW	ln	
Elem(l)	maxQty	NEW	maximum quantity	
Elem(l)	mimeCode	NEW	mime code	
Elem(l)	mime	NEW	mime	
Attrib	operationalCode	NEW	operational code	Has NEW attribute: numbering organisation code
Attrib	operationalCode	NEW	operational code	Has NEW attribute: code list reference
Attrib	operationalCode	NEW	operational code	Has NEW attribute: code qualifier
Attrib	operationalCode	NEW	operational code	Has NEW attribute: code list version
Attrib	operationalCode	NEW	operational code	Has NEW attribute: code list name
Elem(l)	operationalCode	NEW	operational code	

Attrib	otherCurrency	NEW	other currency code	Has NEW attribute: exchange rate
Attrib	productLine	NEW	product line	Has NEW attribute: code list name
Attrib	productLine	NEW	product line	Has NEW attribute: numbering organisation code
Attrib	productLine	NEW	product line	Has NEW attribute: code list reference
Attrib	productLine	NEW	product line	Has NEW attribute: code list version
Elem(I)	productLine	NEW	product line	
Elem(I)	progr	NEW	progressive number	
Elem(E)	project	UPDATED	project identifier	Property: Length_Max Old value: 25 New value: 40
Child	refDoc	NEW	reference document details	Has NEW child of: attachment
Child	refDoc	UPDATED	reference document details	relationship with child: document identifier Property: BestPractice_English Old value: New value: <i>numberingOrg indicates the role that produced the document identifier (it is allowed to declare two different ones -e.g. customer and supplier - with two docID with different numberingOrg)</i>
Attrib	season	NEW	season identifier	Has NEW attribute: code list reference
Attrib	season	NEW	season identifier	Has NEW attribute: numbering organisation code
Attrib	season	NEW	season identifier	Has NEW attribute: code list name
Attrib	season	NEW	season identifier	Has NEW attribute: code list version
Elem(I)	subDept	NEW	department identifier	
Child	supplier	NEW	Supplier (*)	Has NEW child of: Party identifier
Child	supplier	NEW	Supplier (*)	Has NEW child of: Additional Party Identifier
Attrib	supplier	NEW	Supplier (*)	Has NEW attribute: sender Party qualifier
Attrib	legalRef	NEW	tax legal reference	Has NEW attribute: code list name

Attrib	legalRef	NEW	tax legal reference	Has NEW attribute: numbering organisation code
Attrib	legalRef	NEW	tax legal reference	Has NEW attribute: code list version
Attrib	legalRef	UPD ATED	tax legal reference	Its attribute: code list reference Property: Use Old value: <i>Required</i> New value: <i>Optional</i>
Child	dtScheme	UPD ATED	tax scheme	relationship with child: general note Property: Cardmax Old value: 19 New value: 99
Element(E)	payTermText	UPD ATED	terms of payment text	Property: Length_Max Old value: 40 New value: 250
Element(E)	incoTermText	UPD ATED	terms of trade text	Property: Length_Max Old value: 70 New value: 250
Element(E)	method	UPD ATED	test method identifier	Property: Length_Max Old value: 25 New value: 80
Child	thirdParty	NEW	Third Party (*)	Has NEW child of: Party identifier
Attrib	thirdParty	NEW	Third Party (*)	Has NEW attribute: sender Party qualifier
Child	terms	UPD ATED	Trade conditions	relationship with child: Transport information Property: Cardmax Old value: 1 New value: 5
Element(E)	transConditionText	UPD ATED	transport condition - text	Property: Length_Max Old value: 100 New value: 250
Child	transInfo	NEW	Transport information	Has NEW child of: despatch place
Child	transInfo	NEW	Transport information	Has NEW child of: despatch date
Child	transInfo	NEW	Transport information	Has NEW child of: effective delivery date
Attrib	transInfo	NEW	Transport information	Has NEW attribute: progressive number
Attrib	price	NEW	unit price amount	Has NEW attribute: data currency

Element(E)	price	UPDATE	unit price amount	Property: Digits_Dec Old value: 2 New value: 4
Attribute	uri	NEW	uri	Has NEW attribute: is URL
Element(l)	uri	NEW	uri	
Element(E)	yarnCharacterText	UPDATE	yarn characteristics text	Property: Length_Max Old value: 40 New value: 250
Child	yarnComInfo	NEW	Yarn commercial information	Has NEW child of: season identifier
Attribute	yarnComInfo	NEW	Yarn commercial information	Has NEW attribute: end use code
Child	yarnComInfo	NEW	Yarn commercial information	Has NEW child of: product line
Child	yarnComInfo	NEW	Yarn commercial information	Has NEW child of: Brand
Child	yarnComInfo	NEW	Yarn commercial information	Has NEW child of: operational code
Child	yarnComInfo	NEW	Yarn commercial information	Has NEW child of: project identifier
Child	yarnComInfo	NEW	Yarn commercial information	Has NEW child of: general note
Element(E)	yarnOuterWrapText	UPDATE	yarn outer packing text	Property: Length_Max Old value: 40 New value: 250
Child	yarnCode	UPDATE	Yarn product code	relationship with child: description Property: Aggregation Note_English Old value: New value: <i>Product description</i>
Child	yarnCode	UPDATE	Yarn product code	relationship with child: description Property: Cardmax Old value: 1 New value: 999
Element(l)	yarnTreatmentText	NEW	yarn treatment text	

Child	YXheader	UPDATED	YXheader	relationship with child: general note Property: Cardmax Old value: 19 New value: 99
Child	YXheader	UPDATED	YXheader	relationship with child: reference document details Property: Aggregation Note_English Old value: New value: <i>At least one occurrence should contain a reference to the order it responds to (for example docType=ORD or OCH or BOR)</i>
Child	YXitem	NEW	YXitem	Has NEW child of: yarn treatment
Child	YXitem	NEW	YXitem	Has NEW child of: yarn treatment text
Child	YXitem	NEW	YXitem	Has NEW child of: tax scheme
Child	YXitem	UPDATED	YXitem	relationship with child: yarn specifications Property: Cardmax Old value: 9 New value: 99
Child	YXitem	UPDATED	YXitem	relationship with child: Third Party Property: Cardmax Old value: 1 New value: 3
Child	YXitem	UPDATED	YXitem	relationship with child: product quantity Property: BestPractice_English Old value: New value: <i>this element can have two instances only if the units of measure are different</i>
Child	YXitem	UPDATED	YXitem	relationship with child: general note Property: Cardmax Old value: 19 New value: 99
Child	YXitem	UPDATED	YXitem	relationship with child: manufacture lot identifier Property: Aggregation Note_English Old value: <i>it can be specified by the Buyer in case of stock service it can be specified by the Buyer in case of stock service</i> New value: <i>it can be specified by the Buyer in case of stock service it can be specified by the Buyer in case of stock service</i>

Annex D

New or changed tables and codes towards previous version

Changes or added items (changes in CodeListAgencyName excluded; changes in adoption notes and code description included): 164

Test Type	Status	Table code	Table description	Code	Change description
Code	UPDATE	N1		A (the order is open without a concrete delivery of product; it establishes an amount of goods to be produced in a future)	adoption_note Old value: New value: <i>the order is open without a concrete delivery of product; it establishes an amount of goods to be produced in a future</i>
Code	UPDATE	N1		D (orders an amount of goods to be delivered (and invoiced and produced if necessary); it is important that it is clear that this amount should be subtracted from the amount of the blanket order referred in the refDoc element)	adoption_note Old value: New value: <i>orders an amount of goods to be delivered (and invoiced and produced if necessary); it is important that it is clear that this amount should be subtracted from the amount of the blanket order referred in the refDoc element</i>
Table	UPDATE	N10	eBIZ TCFUpstream version		Description_English Old value: <i>eBIZ Moda-ML version</i> New value: <i>eBIZ TCFUpstream version</i>
Code	NEW	N100		2018-1 (v2018-1)	
Code	NEW	N100		draft (draft)	
Table	UPDATE	N16	VAT rate or code		Generalities Old value: <i>VAT rate or code (deprecated , use dtScheme element)</i> New value: <i>VAT rate or code (DEPRECATED, use dtScheme element)</i>
Code	NEW	N2		AU (Auditor)	
Code	NEW	N2		CE (Certification authority)	

C o d e	NE W	N T 2		SC (Sub contractor)	
C o d e	NE W	N T 2		SM (Service/ePlatform manager)	
C o d e	NE W	N T 4		SA (Sample)	
T a b l e	UP DA TE D	N T 4	end use		Generalities Old value: <i>specifies the final use of the fabric</i> New value: <i>specifies the final use of the product</i>
T a b l e	NE W	N T 43	operatio nal code qualifier		
C o d e	NE W	N T 43		1 (event)	
C o d e	NE W	N T 43		2 (sales channel)	
C o d e	NE W	N T 43		3 (goods management type)	
C o d e	NE W	N T 43		4 (special initiative)	
C o d e	NE W	N T 6		EB (eBIZ)	
C o d e	UP DA TE D	N T 6		ML (DEPRECATED)	adoption_note Old value: New value: <i>DEPRECATED</i>
T a b l e	NE W	N T 60	languag e, codes from IS O 639-1 (subset)		

C o d e	NE W	N T 60		<i>F</i> (Female)	
C o d e	NE W	N T 60		<i>af</i> (Afrikaans)	
C o d e	NE W	N T 60		<i>ar</i> (Arabic)	
C o d e	NE W	N T 60		<i>be</i> (Belarusian)	
C o d e	NE W	N T 60		<i>bg</i> (Bulgarian)	
C o d e	NE W	N T 60		<i>bn</i> (Bengali)	
C o d e	NE W	N T 60		<i>bo</i> (Tibetan)	
C o d e	NE W	N T 60		<i>bs</i> (Bosnian)	
C o d e	NE W	N T 60		<i>ca</i> (Catalan, Valencian)	
C o d e	NE W	N T 60		<i>cs</i> (Czech)	
C o d e	NE W	N T 60		<i>da</i> (Danish)	
C o d e	NE W	N T 60		<i>de</i> (German)	
C o d e	NE W	N T 60		<i>el</i> (Greek, Modern (1453-))	

C o d e	NE W	N T 60		<i>en</i> (English)	
C o d e	NE W	N T 60		<i>eo</i> (Esperanto)	
C o d e	NE W	N T 60		<i>es</i> (Spanish, Castilian)	
C o d e	NE W	N T 60		<i>et</i> (Estonian)	
C o d e	NE W	N T 60		<i>eu</i> (Basque)	
C o d e	NE W	N T 60		<i>fa</i> (Persian)	
C o d e	NE W	N T 60		<i>fi</i> (Finnish)	
C o d e	NE W	N T 60		<i>fr</i> (French)	
C o d e	NE W	N T 60		<i>ga</i> (Irish)	
C o d e	NE W	N T 60		<i>gd</i> (Gaelic, Scottish Gaelic)	
C o d e	NE W	N T 60		<i>gn</i> (Guarani)	
C o d e	NE W	N T 60		<i>he</i> (Hebrew)	
C o d e	NE W	N T 60		<i>hr</i> (Croatian)	

C o d e	NE W	N T 60		<i>ht</i> (Haitian, Haitian Creole)	
C o d e	NE W	N T 60		<i>hu</i> (Hungarian)	
C o d e	NE W	N T 60		<i>hy</i> (Armenian)	
C o d e	NE W	N T 60		<i>ia</i> (Interlingua (International Auxiliary Language Association))	
C o d e	NE W	N T 60		<i>id</i> (Indonesian)	
C o d e	NE W	N T 60		<i>is</i> (Icelandic)	
C o d e	NE W	N T 60		<i>it</i> (Italian)	
C o d e	NE W	N T 60		<i>ja</i> (Japanese)	
C o d e	NE W	N T 60		<i>ju</i> (Javanese)	
C o d e	NE W	N T 60		<i>ka</i> (Georgian)	
C o d e	NE W	N T 60		<i>km</i> (Central Khmer)	
C o d e	NE W	N T 60		<i>ko</i> (Korean)	
C o d e	NE W	N T 60		<i>ku</i> (Kurdish)	

C o d e	NE W	N T 60		<i>lb</i> (Luxembourgish, Letzeburgesch)	
C o d e	NE W	N T 60		<i>lo</i> (Lao)	
C o d e	NE W	N T 60		<i>lt</i> (Lithuanian)	
C o d e	NE W	N T 60		<i>lv</i> (Latvian)	
C o d e	NE W	N T 60		<i>mg</i> (Malagasy)	
C o d e	NE W	N T 60		<i>mk</i> (Macedonian)	
C o d e	NE W	N T 60		<i>mn</i> (Mongolian)	
C o d e	NE W	N T 60		<i>mt</i> (Maltese)	
C o d e	NE W	N T 60		<i>nl</i> (Dutch, Flemish)	
C o d e	NE W	N T 60		<i>no</i> (Norwegian)	
C o d e	NE W	N T 60		<i>pl</i> (Polish)	
C o d e	NE W	N T 60		<i>pt</i> (Portuguese)	
C o d e	NE W	N T 60		<i>ro</i> (Romanian, Moldavian, Moldovan)	

C o d e	NE W	N T 60		<i>ru</i> (Russian)	
C o d e	NE W	N T 60		<i>se</i> (Northern Sami)	
C o d e	NE W	N T 60		<i>sk</i> (Slovak)	
C o d e	NE W	N T 60		<i>sl</i> (Slovenian)	
C o d e	NE W	N T 60		<i>sm</i> (Samoan)	
C o d e	NE W	N T 60		<i>so</i> (Somali)	
C o d e	NE W	N T 60		<i>sq</i> (Albanian)	
C o d e	NE W	N T 60		<i>sr</i> (Serbian)	
C o d e	NE W	N T 60		<i>sv</i> (Swedish)	
C o d e	NE W	N T 60		<i>sw</i> (Swahili)	
C o d e	NE W	N T 60		<i>ta</i> (Tamil)	
C o d e	NE W	N T 60		<i>th</i> (Thai)	
C o d e	NE W	N T 60		<i>tr</i> (Turkish)	

C o d e	NE W	N T 60		<i>uk</i> (Ukrainian)	
C o d e	NE W	N T 60		<i>ur</i> (Urdu)	
C o d e	NE W	N T 60		<i>uz</i> (Uzbek)	
C o d e	NE W	N T 60		<i>vi</i> (Vietnamese)	
C o d e	NE W	N T 60		<i>zh</i> (Chinese)	
C o d e	NE W	N T 7		<i>CMK</i> (square centimetre)	
C o d e	NE W	N T 7		<i>CMQ</i> (cubic centimetre)	
C o d e	NE W	N T 7		<i>E37</i> (pixel)	
C o d e	NE W	N T 7		<i>KWH</i> (kilowatthours)	
C o d e	NE W	N T 7		<i>MMK</i> (square millimetre)	
C o d e	NE W	N T 7		<i>MTK</i> (square metre)	
C o d e	NE W	N T 7		<i>CO2TON</i> (ton of CO2)	
T a b l e	UP DA TE D	N T 7	unit of m easure		OtherExternalReferenceURL Old value: New value: http://docs.oasis-open.org/u

					<i>bl/os-UBL-2.1/cl/gc/default/UnitOfMeasureCode-2.1.gc#</i>
T a b l e	UP DA TE D	N T 7	unit of m easure		Description_English Old value: <i>unity of measure</i> New value: <i>unit of measure</i>
C o d e	NE W	T 21		<i>BOR</i> (blanket order)	
C o d e	NE W	T 21		<i>CEO</i> (Certificate of origin)	
C o d e	NE W	T 21		<i>CER</i> (Certificate)	
C o d e	UP DA TE D	T 21		<i>CTR</i> (Contract)	Text_English Old value: <i>contract</i> New value: <i>Contract</i>
C o d e	NE W	T 21		<i>MCI</i> (Visual merchandising instruction)	
C o d e	NE W	T 21		<i>VMI</i> (visual merchandising instructions)	
C o d e	NE W	T 41		<i>1</i> (Agreed settlement)	
C o d e	NE W	T 41		<i>2</i> (Below specification goods)	
C o d e	NE W	T 41		<i>3</i> (Damaged goods)	
C o d e	NE W	T 41		<i>4</i> (Short delivery)	
C o d e	NE W	T 41		<i>7</i> (Payment on account)	
C o	NE W	T 41		<i>8</i> (Returnable container charge included)	

d e					
C o d e	NE W	T 41		9 (Invoice error)	
C o d e	NE W	T 41		10 (Costs for draft)	
C o d e	NE W	T 41		11 (Bank charges)	
C o d e	NE W	T 41		12 (Agent commission)	
C o d e	NE W	T 41		14 (Wrong delivery)	
C o d e	NE W	T 41		15 (Goods returned to agent)	
C o d e	NE W	T 41		16 (Goods partly returned)	
C o d e	NE W	T 41		17 (Transport damage)	
C o d e	NE W	T 41		19 (Trade discount)	
C o d e	NE W	T 41		20 (Deduction for late delivery)	
C o d e	NE W	T 41		21 (Advertising costs)	
C o d e	NE W	T 41		22 (Customs duties)	
C o	NE W	T 41		23 (Telephone and postal costs)	

d e					
C o d e	NE W	T 41		24 (Repair costs)	
C o d e	NE W	T 41		25 (Attorney fees)	
C o d e	NE W	T 41		26 (Taxes)	
C o d e	NE W	T 41		30 (Direct payment to seller)	
C o d e	NE W	T 41		32 (Goods not delivered)	
C o d e	NE W	T 41		33 (Late delivery)	
C o d e	NE W	T 41		35 (Goods returned)	
C o d e	NE W	T 41		36 (Invoice not received)	
C o d e	NE W	T 41		37 (Credit note to debtor/not to us)	
C o d e	NE W	T 41		38 (Deducted bonus)	
C o d e	NE W	T 41		39 (Deducted discount)	
C o d e	NE W	T 41		40 (Deducted freight costs)	
C o	NE W	T 41		41 (Deduction against other invoices)	

d e					
C o d e	NE W	T 41		42 (Credit balance(s))	
C o d e	NE W	T 41		45 (Debit note to seller)	
C o d e	NE W	T 41		46 (Discount beyond terms)	
C o d e	NE W	T 41		48 (Allowance/charge error)	
C o d e	NE W	T 41		49 (Substitute product)	
C o d e	NE W	T 41		50 (Terms of sale error)	
C o d e	NE W	T 41		52 (Wrong invoice)	
C o d e	NE W	T 41		53 (Duplicate invoice)	
C o d e	NE W	T 41		54 (Weight error)	
C o d e	NE W	T 41		55 (Additional charge not authorized)	
C o d e	NE W	T 41		56 (Incorrect discount)	
C o d e	NE W	T 41		57 (Price change)	
C o	NE W	T 41		58 (Variation)	

d e					
C o d e	NE W	T 41		59 (Chargeback)	
C o d e	NE W	T 41		65 (Settlement to agent)	
C o d e	NE W	T 41		66 (Cash discount)	
C o d e	NE W	T 41		70 (Wrong monetary amount resulting from incorrect free goods quantity)	
C o d e	NE W	T 41		72 (Temporary special promotion)	
C o d e	NE W	T 41		73 (Difference in tax rate)	
C o d e	NE W	T 41		74 (Quantity discount)	
C o d e	NE W	T 41		75 (Promotion discount)	
C o d e	NE W	T 41		76 (Cancellation deadline passed)	
C o d e	NE W	T 41		77 (Pricing discount)	
C o d e	NE W	T 41		78 (Volume discount)	
C o d e	NE W	T 41		79 (Sundry discount)	
T a	UP DA	T 41	type of Allowan		Generalities Old value: <i>coded specification of an Allo</i>

bl e	TE D		ce or Ch arge		<i>wance or Charge</i> New value: <i>coded specification of an Allowance or Charge (elaborated from UNE CE 4465)</i>
C o d e	NE W	T 44		CO (company identification code)	